



Water Cooled Screw Chiller *SCW210*



Nominal Cooling Capacity 185 to 1480 kW (R)
Refrigerant: R407c and R134a

Contents

Features	1
MV7 Control	3
Physical Data	5
Unit Performance	8
Chiller Selection	9
Physical Dimensions	10
Piping Schematic	11
Field Wiring Diagram	13
Electrical Data	14
Power Connection	14

Features

STRUCTURE

MULTISTACK Water Cooled Chillers are designed and constructed under the modular technology patent. A chiller bank consists of multiple individual chiller modules connected in parallel to operate as a single machine, with cooling capacity to match the load demand by varying the number of operating modules. The chiller modules start from one module to ten, giving you full flexibility to increase the capacity as your needs increase.

Each chiller module contains independent circuits, with each circuit including a semi-hermetic screw compressor, two separate evaporators, two separate condensers, and sophisticated control and protection equipment. And each module operates as a completely independent refrigeration circuit. Where load demand varies, the controller can change the chiller's capacity accordingly either by control the number of modules in operation or by adjust the capacity stage of the last start up compressor.

The chiller is enclosed within a durable housing and has removable doors for easy access and convenience for maintenance and service.

COMPACT AND SPACE-SAVING

The compact size of each module means easy access via standard lifts. You no longer need special access to install the chiller. In comparison to conventional water cooled chillers you can gain up to 40% more space. Meaning larger capacity chiller can be easily installed in confined and small places.

LOWER INSTALLATION COST

The compact size of each chiller module means easy access via standard lifts. You don't need expensive cranes or special rigging.

Connecting the module is simple – you only have four pipes. An active link connects electrical power. Clip in the control connections and you're in business. Fast.

ADD-ON FLEXIBILITY

As your needs for cooling increases, Multistack has the solution. Being a modular chiller, it has never been easier to expand the system as larger cooling capacity is needed to meet increased building load demands, with no complicated changes to the room, piping system or control system, and all work can be done quite easily.

SAFE AND RELIABLE

Every module works as an independent refrigeration circuit, with adjacent modules operating independently. In the event of a malfunction in the system, the computer selects the next available standby module to provide back up. One failed module will not disrupt the other chillers or system, giving you total piece of mind.

PEAK ECONOMY AT ALL LOADS

Automatic scheduling of the compressors allows the chiller to match the fluctuating cooling loads and conserve energy with each individual unit running at its peak efficiency. This is much more economical when compared to a large single unit running at part load.

UNPARALLELED RELIABILITY

Every Multistack slave module is identical to each other, so in the event of a malfunction in the system, the computer automatically selects the next available standby circuit to provide back up. For critical air conditioning and industrial process cooling a Multistack modular chiller inherently provides economical standby capacity and unparalleled dependability.

SCREW COMPRESSOR

Each module contains a high efficiency semi-hermetic screw compressor. The refrigerant drawn into the compressor flows evenly over the motor sealed inside the compressor case, and cools down the motor thoroughly. This ensures the motor is always working at the ideal temperature condition.

The compressor has four stage capacity controls: 25%, 50%, 75%, 100%. This is accomplished through a slide valve regulating mechanism. Among all the compressors in operation, the last actuated compressor will run at a three stage capacity control mode to meet the load demand more precisely and keep the chiller running at peak efficiency.

There is also a built in pressure relief feature inside the compressor to by-pass pressure from the discharge to the pressure section whenever the discharge pressure is abnormal. This feature will protect the chiller from damage and prevent loss for refrigerant leakage.

CONDENSER AND EVAPORATOR

Stainless steel 316 brazed plate heat exchanger; Vacuum brazed, endure working pressure of 2.0MPa, small size and light weight, high heat transfer efficiency.

PRE-CHARGED REFRIGERANT

R407C and R134a available for standard chiller; less refrigerant charge required and the Refrigerant charged prior to shipment and undergone performance test

INTERNAL WATER STRAINER

Internal water strainer is made under the Multistack's patent technology, and made from stainless steel. Internal water strainers are supplied and fixed inside both chilled water header pipes and condenser water header pipes for each module, being easily removed when required. The internal water strainer can prevent particles contained in the water from getting into the heat exchanger.

MODEL NUMBER DESIGNATION

SC	W	210	C	-	6	A	.	R	V
1	2	3	4		5	6	7	8	9

1: Screw compressor

2: Cooling type:

A: Air cooled

W: Water cooled

3: Model Number

4: Chiller type

C: Cooling Only

5: The number of modules per chiller (1~8)

6: Electrical Specifications

A: 400V ± 10%/50Hz/3Ph

B: 380V/60Hz/3Ph

C: AC440-460V/60Hz/3Ph

7: Configuration

Blank for Standard

8: Refrigerant

E: R134a

R: R407c

9: Water system

V: Variable Water Flow (VWF)

Blank for standard

*VWF price to be advised on request

MV7 Control

The MV7 computer monitors the chiller's operation and schedules the on and off of each compressor and capacity control stages with respect to the change in load demand. The computer continuously and comprehensively monitors the total operation of all modules in the chiller bank. It will also shut down individual module or the entire bank in the event that a fault occurs. A maximum of 32 refrigeration circuits can be monitored at one time.

System data and Variables Display

The controller's 7" touch panel not only can display the chiller's operation data but also provides direct access to all of the chillers setting and variables for total system control.

Chiller operation status

- chilled water temperature
- condenser water temperature
- % of chiller cooling capacity
- % demand loading
- load / unload time delay
- current fault number
- % of loading limitation
- lead compressor

Module operation status

- compressor suction pressure
- compressor discharge pressure
- evaporating temperature
- chilled water leaving temperature
- faults status

Chiller variables settings

- password
- chilled water temperature
- lead compressor
- temperature integrating time
- economy offset
- load / unload time delay
- time and date



COMPRESSOR SEQUENCE

The MV7 controller accumulates the running hours of each compressor and hence establishes working sequence. A standby compressor with the least working hours will be activated during loading. The same goes for a compressor with the most working hours will be stopped during unloading. This ensures each compressor in the system has an even usage, which will save you time and money in the long run for maintenance.

FAULT REVIEW

The controller will record and display the last 60 faults that occurred, giving detailed information such as time, date, location, cause, current status, as well as the performance data collected at the moment each fault occurred.

LOAD PROFILE

The controller records all working hours of the chiller and compressor and records it accordingly in 10% brackets from 0% - 100%, giving you detailed information for which percentage the chiller is running mostly.

PASSWORD

A two level password protection is included (for both customer and service personnel) to give you piece of mind. For example the service password will give you full access to settings and variables, but the user password will only enable the user see but not change settings and variables.

STANDBY CONTROL

Each module can be set for three modes: auto/ off/independent operation via the slave outstation card installed in the module. Default setting is “auto”, with “off” mode for when maintenance is required and “independent” mode (where the module is controlled by its own slave outstation card and operates independently from the controller), is usually for commissioning or emergency operation.

REMOTE CONTROL & MONITORING (OPTIONAL)

- 1) If direct RCM functionality is required, the MV7 HMI computer will be assembled with an Ethernet port, allowing it to be fully managed from a remote computer via a VNC Client/Server protocol.
- 2) If BAS Communication is required, the MV7 System will be fitted with a BacNet IP/MSTP Gateway.

Physical Data

Per Module

Model		SCW 210	
Refrigerant type		R407c	R134a
Nominal Cooling Capacity (kW)		185.1	162.6
Nominal Power Input (kW)		45.2	35.9
Compressor	Type	Semi-hermetic Screw Compressor	
	Number	1	
	Capacity Stages per module (%)	50, 75, 100	
Evaporator	Type	Braze Plate Type Stainless Steel AISI 316	
	Number	2	
	Nominal Flow Rate (L/s)	8.9	7.8
	Water Pressure Drop (kPa)	56	45
	Fouling Factor (m ² k/kW)	0.018	
	Max. Working Press. (Refrigerant side) (kPa)	2400	
	Max. Working Press. (Water Side) (kPa)	2000	
Water Connection (Pipe size)	8"		
Condenser	Type	Braze Plate Type Stainless Steel AISI 316	
	Number	2	
	Nominal Water Flow (L/s)	11	9.5
	Water Pressure Drop (kPa)	50	40
	Fouling Factor (m ² k/kW)	0.044	
	Max. Working Press. (Refrigerant side) (kPa)	2400	
	Max. Working Press. (Water side) (kPa)	2000	
Water Connection (Pipe size)	8"		
Refrigerant charge (kg)		20	16
Shipping weight (kg)		1300	
Operation weight (kg)		1390	
Dimension (L x W x H) mm		2030 x 550 x 1895	

Nominal Values based on:

- Chiller Water Entering Temp. 12°C
- Chilled Water Leaving Temp. 7°C
- Condenser Water Entering Temp. 30°C
- Condenser Water Leaving Temp. 35°C

Note:

- Minimum Chilled Water Flow Rate Per Module: Nominal Water Flow Rate Less 10%
- Minimum Condenser Water Flow Rate Per Module: Nominal Water Flow Rate less 10%
- For low temperature applications (≤6°C) contact Multistack Ltd.

CONDENSER WATER QUALITY GUIDE

The following parameters are recommended as a guide for optimum quality of the water circulating through the condenser cooling tower circuit

Conditions	Maximum	Affects Corrosion	Affects Scaling
Total dissolved solids (TDS)	700 ppm	Yes	Yes
Conductivity	1000uS/cm	Yes	Yes
Sulphate ions (as SO_4^{2-})	200 ppm	Yes	
All iron (as Fe)	0.5 ppm		Yes
M alkalis (as $CaCO_3$)	100 ppm		Yes
All hardness (as $CaCO_3$)	200 ppm		
Silica (as SiO_2)	50 ppm		Yes

Chloride ions (as Cl^-) for materials below:

Stainless Steel 316	400 ppm	Yes	
pH @ 25.0 °C Range: 6 - 8		Yes	Yes

Note:

Corrosion and/or scaling may result from an excess of one condition but water quality should satisfy all conditions to prevent its occurrence. It is recommended

HEAT EXCHANGER WATER PRESSURE DROP

Pressure drop correction factor for chilled and hot water circuit

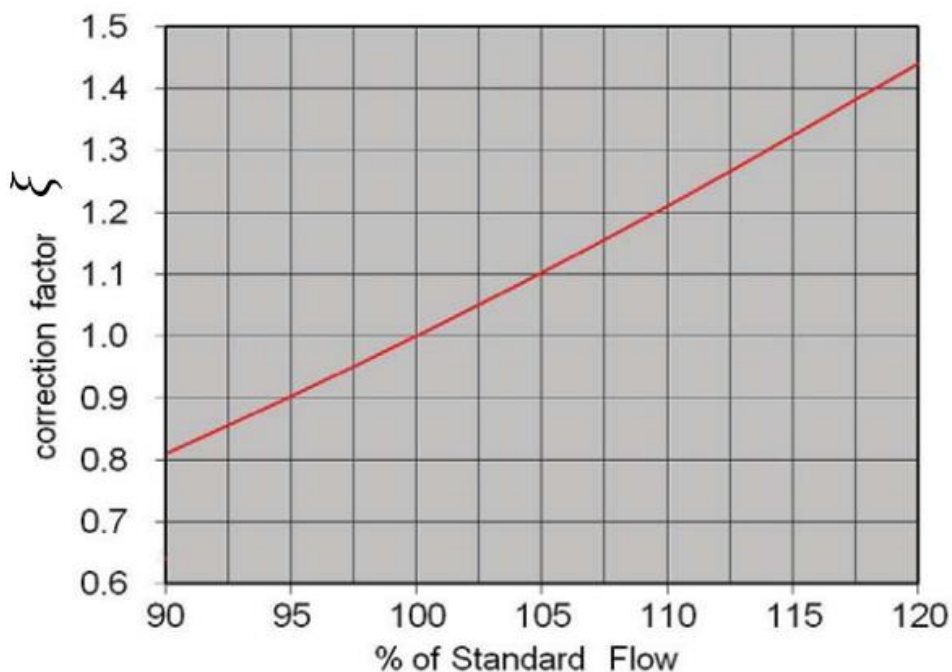

PRESSURE DROP CORRECTION FACTOR (ξ)

1. Water pressure drop calculation

$$\text{Water flow \%} = \frac{\text{Actual water flow}}{\text{Nominal water flow}} \times 100$$

Heat exchanger actual water pressure drop per module

$$= \text{heat exchanger nominal water pressure drop} \times \xi$$

β is related to total number of modules (N) in the chiller bank

N	1	2	3	4	5	6	7	8
β	1	1	1.01	1.02	1.03	1.04	1.05	1.06

Total water pressure drop per chiller = heat exchanger actual water pressure drop per module $\times \beta$

2. Chiller minimum working water flow

- (1) Constant water flow system, no less than 90% of chiller total nominal water flow
- (2) Variable water flow system: no less than 90% of module nominal water flow

Unit Performance

Per Module

Leaving Condenser Water temp. °C	Leaving Chilled Water Temperature °C									
	R407c									
	6		7		8		10		12	
	CAP	PI	CAP	PI	CAP	PI	CAP	PI	CAP	PI
30	190.8	40.8	198.2	41.1	205.8	41.4	221.7	42.2	238.5	43.0
35	177.9	45.0	185.1	45.2	192.2	45.2	207.4	46.1	223.4	46.8
37	172.5	46.8	179.4	47.1	186.6	47.1	201.4	47.9	217.2	48.5
40	164.2	49.9	170.9	50.1	177.9	50.3	192.3	50.8	207.6	51.3
45	149.6	55.5	156.0	55.7	162.7	55.9	176.4	56.3	191.0	56.7

Leaving Condenser Water temp. °C	Leaving Chilled Water Temperature °C									
	R134a									
	6		7		8		10		12	
	CAP	PI	CAP	PI	CAP	PI	CAP	PI	CAP	PI
30	165.9	32.5	173.0	32.8	180.4	33.1	195.8	33.7	212.2	34.4
35	155.9	35.6	162.6	35.9	169.7	36.2	184.4	36.8	200.1	37.5
37	151.6	37.0	158.3	37.3	165.2	37.6	179.7	38.2	195.1	38.9
40	145.1	39.2	151.6	39.5	158.3	39.8	172.3	40.4	187.2	41.1
45	133.9	43.3	140.0	43.6	146.3	43.9	159.5	44.5	173.7	45.1

Note:

CAP Cooling Capacity (kW)

PI Compressor Power input (kW)

- This table is based on a 5°C difference in water temperature.
- Please contact your local Multistack Agent if you require performance data beyond the limits of the above table.
- Interpolation is permissible. Do not extrapolate.

Chiller Selection

SELECT WATER-COOLED CHILLER ACCORDING TO FOLLOWING CONDITIONS:

1. Chiller Cooling Capacity Required..... 890kW
2. Entering Chilled Water temperature (ECHW).....12°C
3. Leaving Chilled Water temperature (LCHW).....7°C
4. Entering Condenser Water temperature (ECW).....30°C
5. Leaving Condenser Water temperature (LCW).....35°C
6. Refrigerant.....R407C

Calculation

1. From capacity chart on previous page,

1 module at stated conditions will achieve;

CAP= 185.1 kW per module

$$\text{Required Number of Modules} = \frac{\text{Cooling Capacity Required}}{\text{CAP per Module}} = \frac{890 \text{ kW}}{185.1 \text{ kW}} = 4.8$$

- ∴ Select 5 modules

The total cooling capacity of the chiller is:

$$\text{Number of Modules} \times \text{CAP} = 5 \times 185.1 = 925.5 \text{ kW}$$

$$\text{The capacity residue} = \frac{(925.5 - 890)}{890} \times 100\% = 4.0\%$$

- ∴ The calculation result is acceptable

2. Chilled water pressure drop calculation

(1) Nominal Water Flow = Number for Modules x Evaporator Water Flow

$$\begin{aligned} &= 5 \times 8.9 \\ &= 44.5 \text{ L/s} \end{aligned}$$

(2) Evaporator water pressure drop for nominal water flow per module is 56 kPa

Use the table Pressure drop correction factor: β , $\beta=1.03$ for the configuration: 5 modules.

Actual Evaporator water pressure drop is = $56 \times 1.03 = 57.68 \text{ kPa}$

3. Condenser water flow and pressure drop calculation:

(1) Condenser water flow = Number of Modules x Condenser Water Flow

$$\begin{aligned} &= 5 \times 11 \\ &= 55 \text{ L/s} \end{aligned}$$

(2) Condenser water pressure drop for nominal water flow per module is 50 kPa

Use the table Pressure drop correction factor: β , $\beta=1.03$ for the configuration: 5 modules.

Actual condenser water pressure drop is = $50 \times 1.03 = 51.5 \text{ kPa}$

Physical Dimensions

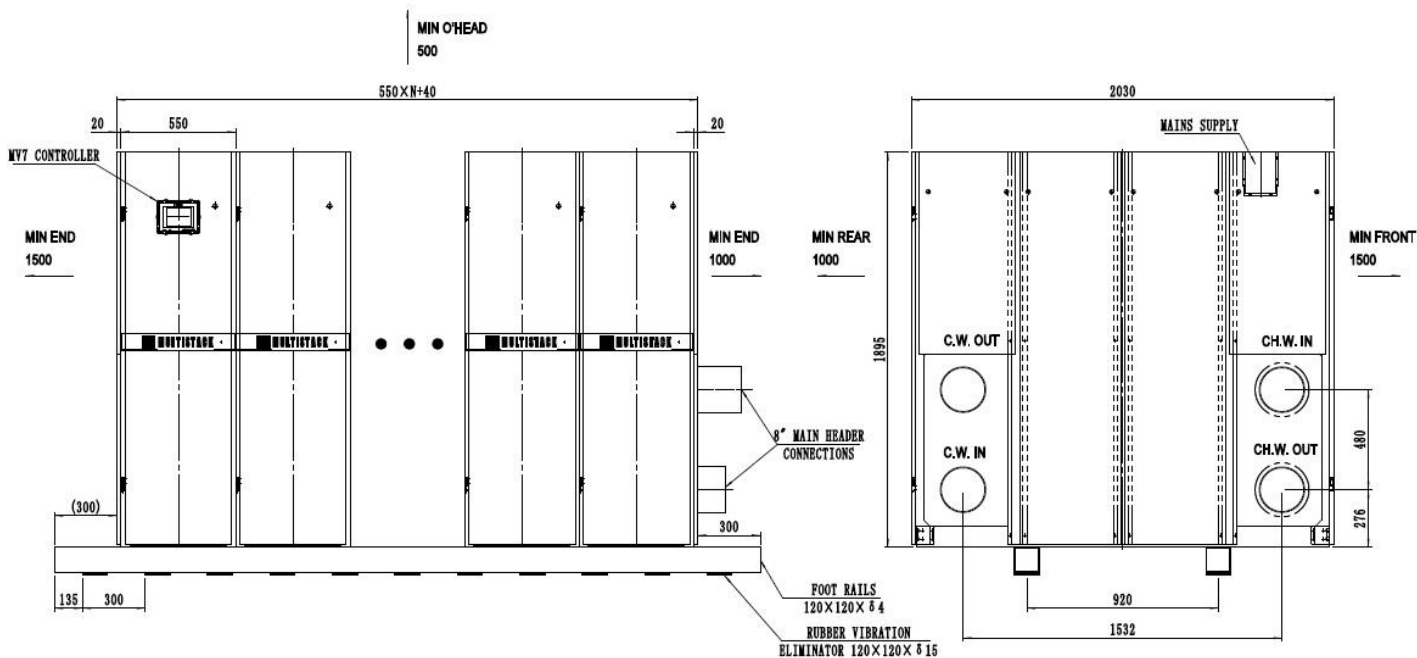

Notes:

All installations must include the following:

Description	Remarks
3/8" BSP socket in all water connections adjacent to chiller for Multistack sensor installation.	Supplied by manufacturer
40 Mesh stainless strainers in water inlet piping	
Cooling tower by-pass control or other system to prevent over condensing	Not supplied by manufacturer
Pressure Tapings for Flow measurement	

1. Electrical mains entry may be made from either end of unit. Some larger machines (determined by the current draw & cable size) require mains entry at both ends. Refer to electrical installation data for isolation information and determination.
2. Chilled and condenser water connections may be interchanged for end to end as required

Piping Schematic

CHILLED WATER PIPING PARTS

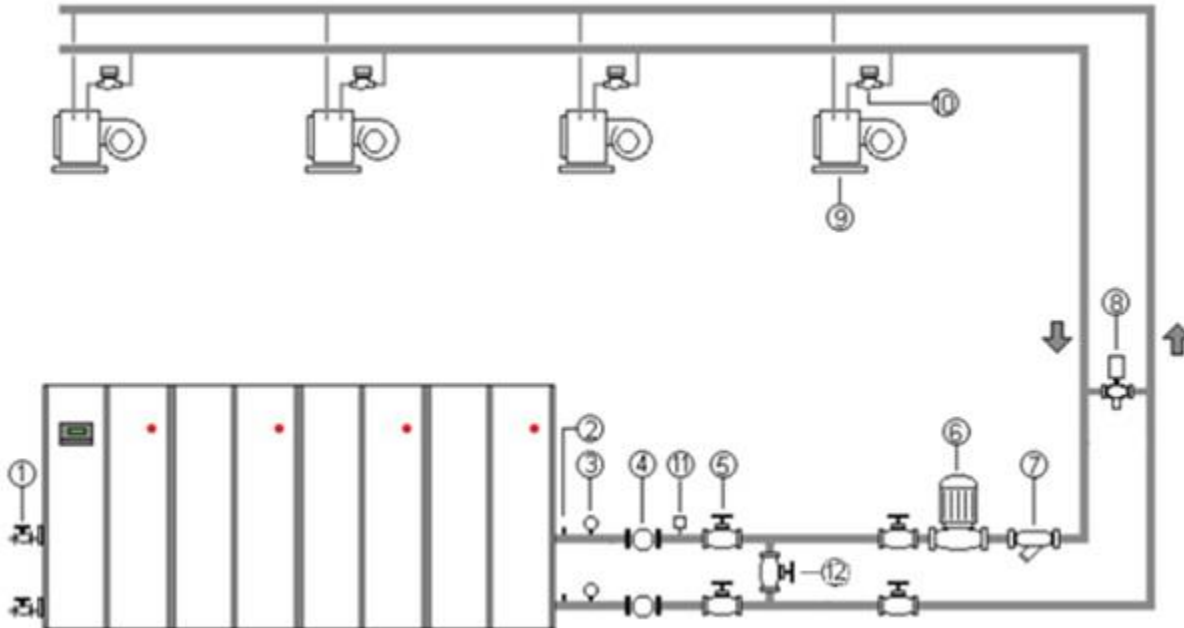

Item	Description	Qty	Remarks
1	Drain Valve DG50	2	Supplied by others
2	Chilled Water Temp Sensor	2	Supplied by manufacturer
3	Pressure Gauge	2	Supplied by others
4	Vibration Eliminator	2	
5	Isolation Gate Valve	5	
6	Water Pump		
7	Water Strainer	1	
8	Chiller side differential pressure by-pass valve	1	
9	Terminal air handling equipment		
10	Motorized valve	1	
11	Water flow switch	1	
12	Back Flush By-Pass Valve (*)	1	

Notes:

- Customer's responsibility for all piping parts, except those included with the chiller.
- During the whole installation process, the isolation gate valves on both entering/leaving line to the chiller should be closed. The valves will remain closed until the piping installation; leakage check and cleaning are all completed.
- To prevent stress on the headers and Victaulic couplings all water pipe work must be properly supported.
- To prevent water accumulation inside the sensor socket grease should be filled in the sensor socket before inserting the chilled water temperature sensor.
- (*) The chiller's piping system should be cleaned thoroughly to get rid of any mechanical debris prior to operation. During pipe cleaning, close chiller's entering/leaving isolation gate valves and open the bypass valve to prevent the water circulation through the chiller.
- (*) During chiller operation back flush by-pass valve must be closed.

CONDENSOR WATER PIPING PARTS

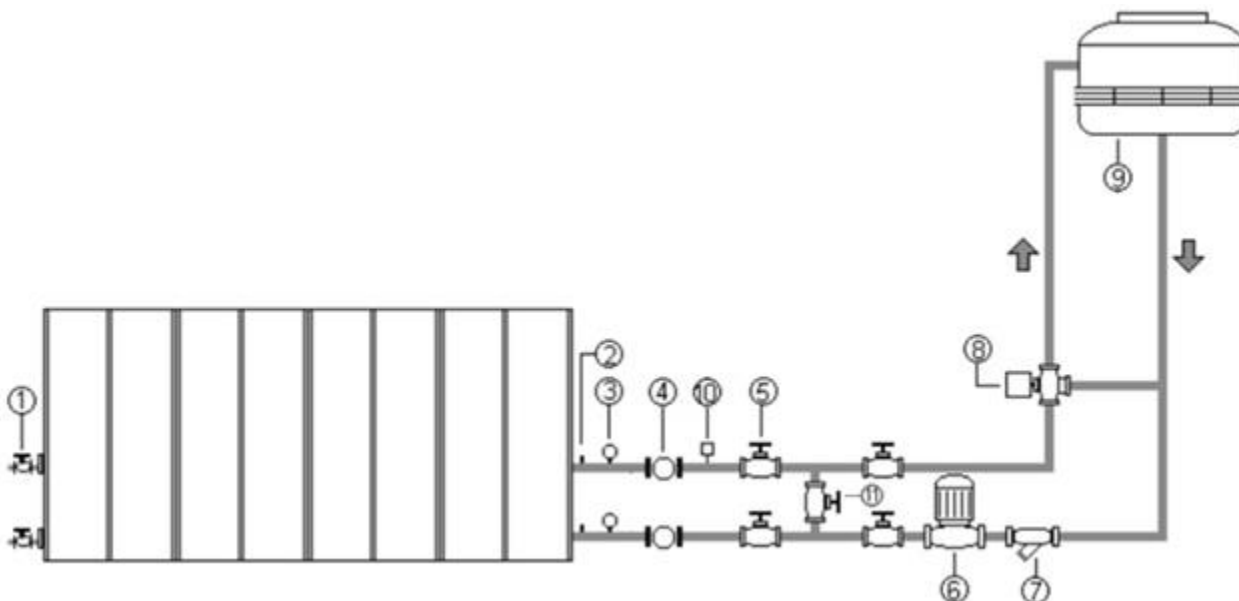

Item	Description	Qty	Remarks
1	Drain Valve DG50	2	Supplied by others
2	Condenser water temperature sensor	2	Supplied by manufacturer
3	Pressure Gauge	2	Supplied by others
4	Vibration Eliminator	2	
5	Isolation Gate Valve	5	
6	Water Pump		
7	Water Strainer	1	
8	Condenser water by-pass proportion regulating valve	1	
9	Cooling tower		
10	Water flow switch	1	
11	Back Flush By-Pass Valve (*)	1	

Notes:

1. It is the customer's responsibility to supply all piping parts, except for those supplied with the chiller.
2. The condenser water by-pass proportion regulating valve will not be necessary if the cooling tower fan is controlled by the condenser water leaving temperature.
3. The condenser water can be controlled by the cooling tower fan or condenser water by-pass, its leaving temperature shouldn't exceed 25% to prevent the compressor from operating at low suction pressure.
4. During the whole installation process, the isolation gate valves on both entering /leaving line to the chiller should be closed. The valves will remain closed until the piping installation; leakage check and cleaning are all completed.
5. To prevent stress on the headers and Victaulic couplings all water pipe work must be properly supported.
6. To prevent water accumulation inside the sensor socket grease should be filled in the sensor socket before inserting the chilled water temperature sensor.
7. (*) The chiller's piping system should be cleaned thoroughly to get rid of any mechanical debris prior to operation. During pipe cleaning, close chiller's entering/leaving isolation gate valves and open the bypass valve to prevent the water circulation through the chiller.
8. (*) During chiller operation the back flush by-pass valve must be closed.

Field Wiring Diagram

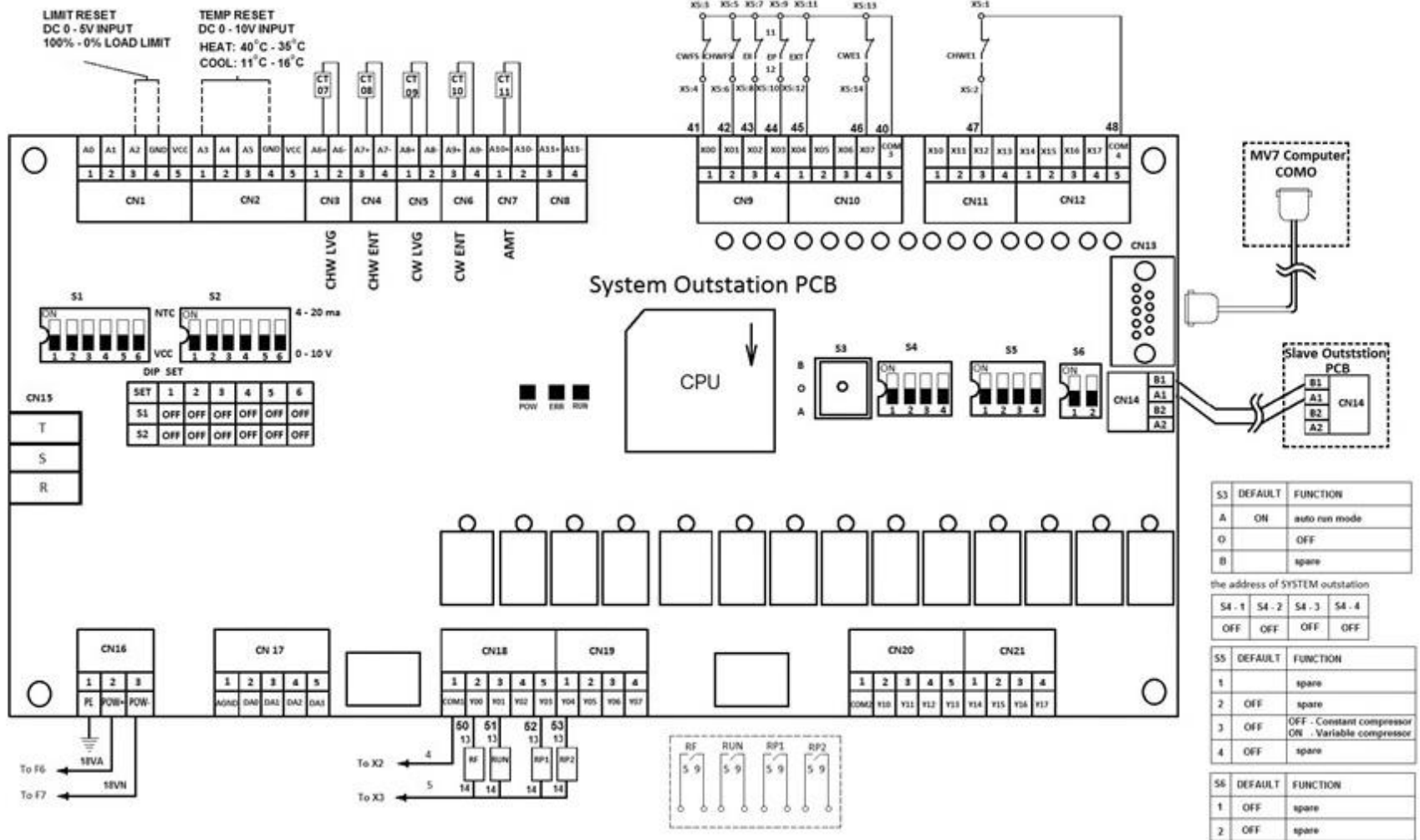

CT11	white	AMBIENT	EXT	Remote Control	CWF5	Cooling Water Flow Switch
CT10	green	ENT CW TEMP	CWE1	Cooling Water Pump Alarm	CHWFS	Chilled Water Flow Switch
CT09	black	LVG CW TEMP	CHWE1	Chilled Water Pump Alarm	RP2	Chilled Water Pump Relay
CT08	red	ENT CHW TEMP	EII	External Interlock Input	RP1	Cooling Water Pump Relay
CT07	yellow	LVG CHW TEMP	gp	Emergency Stop Switch	RUN	Chilled Run Relay
X2 - X3		Terminals			gp	Error Alarm Relay

Electrical Data

Model		SCW 210	
Refrigerant		R407c	R134a
Power		AC400V ± 10% / 50Hz / 3Ph	
Compressor (each)	MCC (A)	128	
	RLA (A)	81	73
	LRA (A)	290	

N	Num. of Compressors	R407c		R134a	
		RLA (A)	LRA (A)	RLA(A)	LRA (A)
1	1	81	290	73	290
2	2	162	371	146	363
3	3	243	452	219	436
4	4	324	533	292	509
5	5	405	614	365	582
6	6	486	695	438	655
7	7	567	776	511	728
8	8	648	857	584	801

Notes:

N:	No. of modules	MCC:	Maximum Continuous Current
LRA:	Locked Rotor Amperage	RLA:	Rating Load Amperage

- When selecting mains cable size, apply allowances for voltage imbalance, under voltage ambient temperature and other conditions in compliance with relevant local electrical codes.
- When starting the chiller, the compressor is start up one at a time. The chiller starting current is equal to the total current of operating compressors plus the starting current of the compressor.

Power Connection

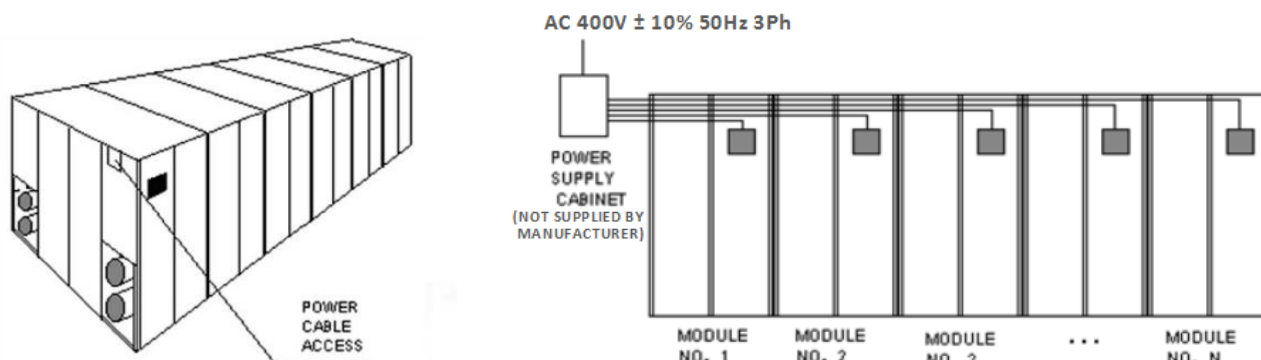

Notes:

1. Electrical mains entry can be made at either end of the chiller.
2. Power cables must be connected to each individual module.
3. When selecting mains cable size use RLA.
4. Allowances must be made for voltage imbalance, ambient temperature and other conditions in compliance with AS 3000 or local relevant electrical codes.

Power distribution cabinet (supplied by customer) should provide equal numbers of power cables connecting to each module.



MULTISTACK INTERNATIONAL LIMITED

17 FRIARS ROAD, MOORABBIN, VICTORIA 3189, AUSTRALIA

TELEPHONE: +61 3 8586 8200 FACSIMILE: +61 3 8586 8202

Email: sales@multistack.com.au

Website: <http://www.multistack.com.au/>

Since MULTISTACK INTERNATIONAL LIMITED has a policy of continuous product improvement,
it reserves the right to change design and specification without notice.
Multistack supplied by Multistack Australia Pty Ltd (a wholly owned subsidiary of Multistack International Limited)
09/2018 Rev. 1.0