



DUNNAIR
(Aust) Pty Ltd

R410a Refrigerant

SHS8

Split Ducted Model

Performance Data

INDOOR COIL ENTERING AIR TEMP °C		OUTDOOR COIL ENTERING AIR TEMPERATURE °C											
		30°C			35°C			40°C			45°C		
		Tot Cap KW	Sens Cap KW	LWB °C	Tot Cap KW	Sens Cap KW	LWB °C	Tot Cap KW	Sens Cap KW	LWB °C	Tot Cap KW	Sens Cap KW	LWB °C
DB °C	WB °C												
21	17	8.0	4.9	11.2	7.5	4.7	11.4	7.1	4.6	11.8	6.8	4.6	12.0
	18	8.2	4.4	11.6	7.7	4.2	12.6	7.3	4.1	12.8	7.0	3.9	13.0
	19	8.5	3.8	13.2	7.7	3.7	12.8	7.6	3.5	13.8	7.3	3.4	14.0
	20	8.8	3.3	14.2	8.3	3.2	14.5	7.9	3.0	14.8	7.6	2.9	15.0
23	17	8.0	5.9	11.1	7.6	5.7	11.4	7.1	5.5	11.7	6.8	5.4	12.0
	18	8.2	5.4	12.2	7.7	5.2	12.3	7.3	5.0	12.7	7.0	4.9	12.9
	19	8.5	4.4	14.2	7.8	4.3	13.4	7.6	4.2	13.8	7.3	4.2	14.0
	20	8.8	4.3	14.2	8.3	4.2	14.4	7.8	4.0	14.8	7.6	3.9	15.0
	21	9.1	3.7	14.4	8.3	3.6	14.8	8.1	3.4	15.7	7.9	3.3	15.8
25	17	8.0	6.7	11.1	7.6	6.5	11.4	7.2	6.3	11.7	6.9	6.1	12.0
	18	8.2	6.5	12.2	7.8	6.4	12.5	7.3	5.8	12.8	7.0	5.8	13.0
	19	8.5	6.3	13.1	7.8	6.2	13.4	7.6	5.4	13.7	7.3	5.3	14.0
	20	8.8	6.0	14.2	8.0	5.6	14.5	7.8	5.0	14.8	7.5	4.8	15.0
	21	9.1	5.7	15.4	8.3	5.1	15.5	8.1	4.4	15.6	7.9	4.3	15.8
27	17	8.0	7.5	11.0	7.6	7.2	11.4	7.4	7.0	11.5	7.1	6.8	11.7
	18	8.2	7.2	12.1	7.7	6.8	12.3	7.5	6.8	12.6	7.2	6.6	12.8
	19	8.5	7.0	13.1	7.8	6.8	13.2	7.6	6.5	13.7	7.3	6.4	13.9
	20	8.8	6.8	14.2	8.1	6.6	14.3	7.8	5.9	14.8	7.5	5.8	15.0
	21	9.1	6.3	15.1	8.3	6.1	15.5	8.2	5.5	15.7	7.9	5.4	15.8
29	17	8.0	8.0	10.9	8.0	7.9	11.1	7.6	7.5	11.3	7.3	7.3	11.5
	18	8.2	7.9	11.9	8.1	7.7	12.2	7.7	7.4	12.5	7.4	7.2	12.7
	19	8.5	7.6	13.0	8.2	7.5	13.3	7.7	7.3	13.5	7.4	7.1	13.7
	20	8.8	7.2	14.1	8.3	7.1	14.4	7.9	6.9	14.7	7.6	6.8	14.9
	21	9.1	6.7	15.1	8.6	6.6	15.3	8.1	6.4	15.6	7.8	6.3	15.8
31	17	8.0	8.0	11.3	8.3	8.3	11.3	7.9	7.9	11.3	7.7	7.7	11.3
	18	8.2	8.0	11.7	8.3	8.2	11.9	7.9	7.9	12.2	7.7	7.7	12.4
	19	8.5	8.3	12.9	8.4	8.1	13.1	7.9	7.8	13.4	7.7	7.7	13.6
	20	8.8	8.2	14.1	8.4	8.0	14.4	7.9	7.8	14.7	7.7	7.7	14.9
	21	9.1	7.8	15.1	8.4	7.6	15.3	8.1	7.4	15.6	7.9	7.3	15.8

Capacity multipliers should be applied to the above capacities to adjust for reduced or increased air flow.

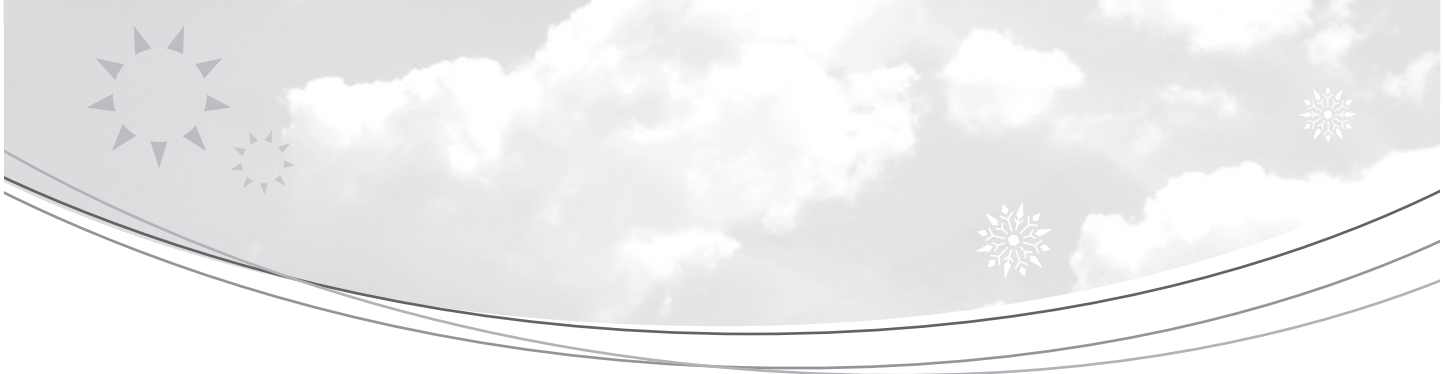

Technical Specification SHS8 Split Ducted Model

Indoor Unit Model Number	SHS8N	Nominal Evaporator Air Flow (l/s)	472
Outdoor Unit Model Number	SHS8W	External Static Pressure	100
Total Cooling Capacity (kW)*	7.8	Number of Compressors	1
Sensible Cooling Capacity (kW)*	6.8	Power Requirements (Volt / Phase)	240 / 1
Heating Capacity (kW)**	7.4	Normal Max. Current (Amps / Phase)	15.1

*Entering air @ 27/19°C and ambient 35°C ** Entering air @ 21°C DB and 7°C ambient

Air Quantity Multiplying Factors

% Rated Air Quantity-Nominal 472 l/s					
Capacity	80	90	100	110	120
Total	0.95	0.98	1.00	1.02	1.04
Sensible	0.89	0.95	1.00	1.05	1.09

Heating Performance Data

Outdoor Coil Entering DB temp					
	0	4	8	12	18
Heating Capacity kW	6.5	6.9	7.9	8.7	10.2

Heating Performance Correction

% Rated Air Quality	Multiplier	Return Air Temp °C	Multiplier	Outdoor Air Temp °C	Approx. Defrost Factor
80	0.93	15	1.05	0	0.80
90	0.97	18	1.03	2	0.78
100	1.00	21	1.00	4	0.75
110	1.03	24	0.97	6	0.87
120	1.05	27	0.95	8	1.06

Compressor

Number Per Unit	1
Type	Rotary
RPM (Nom)	2900
Normal Max. Current (Amps / Phase)	12.4
Locked Rotor Current (Amps / Phase)	80.5
Displacement (m ³ /h)	10.1

Electrical Controls and Safeties

High Pressure Switch (Setting kPa)	2800	Defrost	
Low Pressure Switch (Setting kPa)	100	Initiation Temperature (°C)	-4
Indoor Fan Overload	Internal	Termination Temperature (°C)	10
Outdoor Fan Overload	Internal	Min. Period Between De-Ice (min)	33
Compressor Delay Timer	300 sec	Max. De-Ice Period (min)	4

Standard Features

Manual reset high pressure and auto reset low pressure cutouts	
Thermal overload protection on all motors	Suction line accumulator
Compressor crankcase heater	Automatic de-ice system
Limit start timer (anti short cycling)	Thermally insulated indoor unit

Indoor Coil

Type	Copper Tube / Aluminium Fins
Face Area (m)	0.3
Air Quantity (l/s)	472

Indoor Fan

Number of Fans	1
Type	Centrifugal
Drive	Direct
Motor Voltage / Phase / Frequency	240 / 1 / 50
Motor (kW) Standard	0.2
Max. Fan Speed (rpm)	1131

Electrical

Power Requirements	1 Phase / 240V / 50Hz
Normal Max. Current (Amps / Phase)	15.1

Outdoor Coil

Type	Copper Tube / Aluminium Fins
Face Area	0.65

Outdoor Fan

Number of Fans	1
Type	Axial
Drive	Direct
Motor Watts / rpm	40 / 920
Motor Voltage / Phase / Frequency	240 / 1 / 50

Refrigerant System

Refrigerant Type	R410a
Charge (kg)	2.8
Line Size (mm)	
Liquid 0–10 metres	10
Gas 0–10 metres	16
Liquid 10–20 metres	–
Gas 10–20 metres	–
Service Connections	Rotor Lock Valve
Expansion Control – in outdoor unit	Capillary

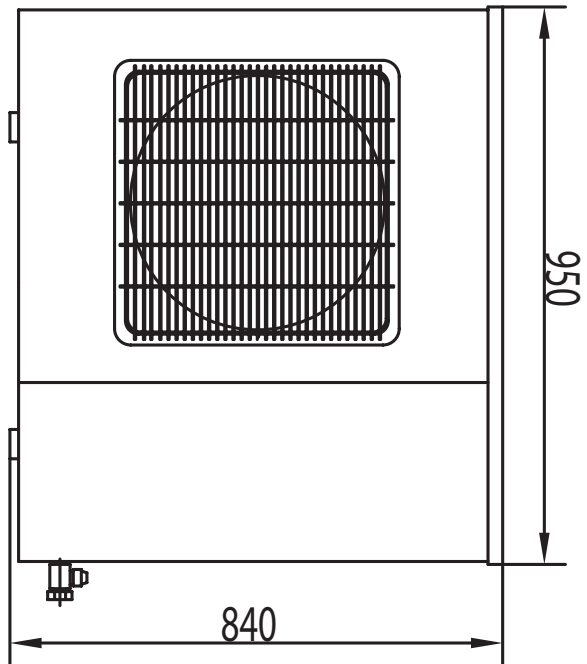
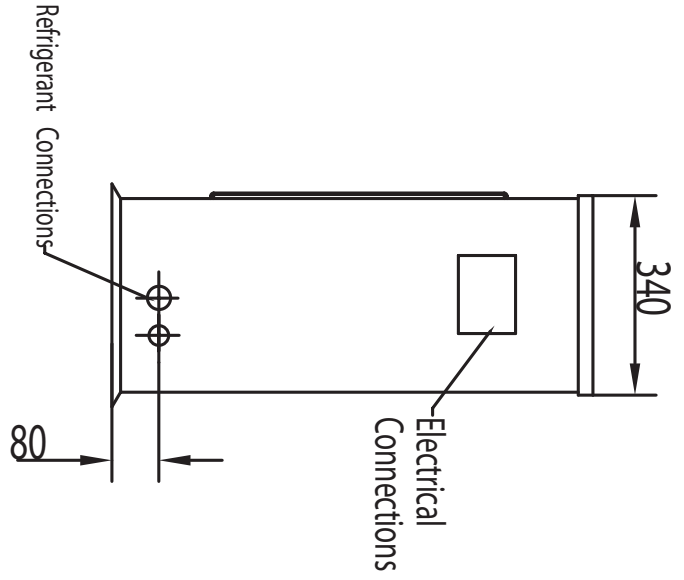

OUTDOOR UNIT INSTALLED WEIGHT 77 kg

For units with

R410a/R407C/R22

DRAWN BY: Chen Cheng		DATE: 7th Jan.10		TITLE: Split System Air Cooled Heat Pump Unit	
APPROVED QA: Li Meifen		APPROVED ENG.: Zhang Jingfei		SHS TYPE	
MODEL: SHS8WBd2	DRAWING NO.: 01	ISSUE: 01	SHEET SIZE: A4		

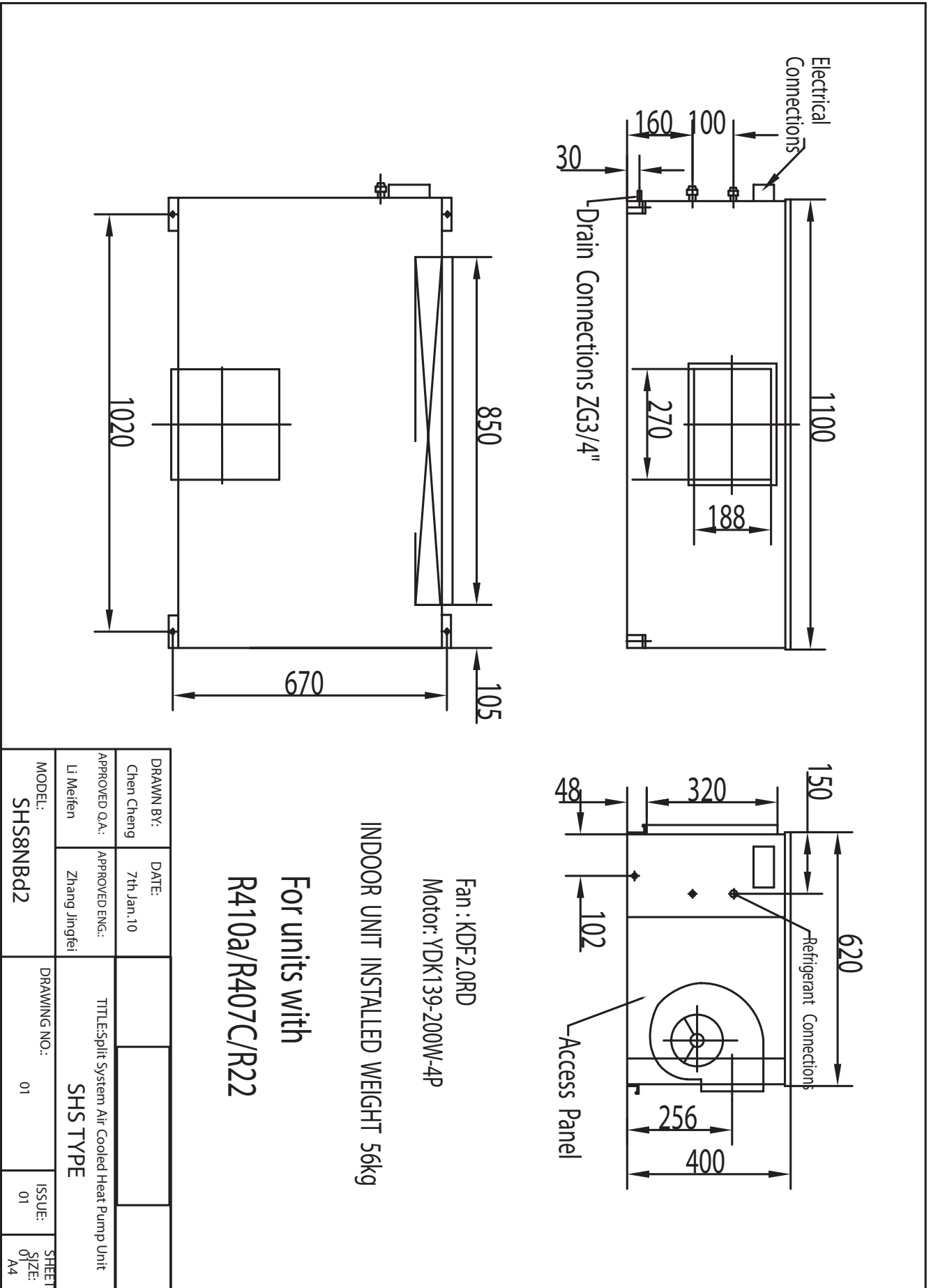

Fan : KDF2.0RD
 Motor: YDK139-200W-4P

INDOOR UNIT INSTALLED WEIGHT 56kg

For units with
 R410a/R407C/R22

DRAWN BY: Chen Cheng	DATE: 7th Jan.10		
APPROVED Q.A.: Li Meifen	APPROVED ENG.: Zhang Jingfei	TITLE:Split System Air Cooled Heat Pump Unit	
MODEL: SHS8NBd2	DRAWING NO.: 01	ISSUE: 01	SHEET SIZE: A4
SHS TYPE			

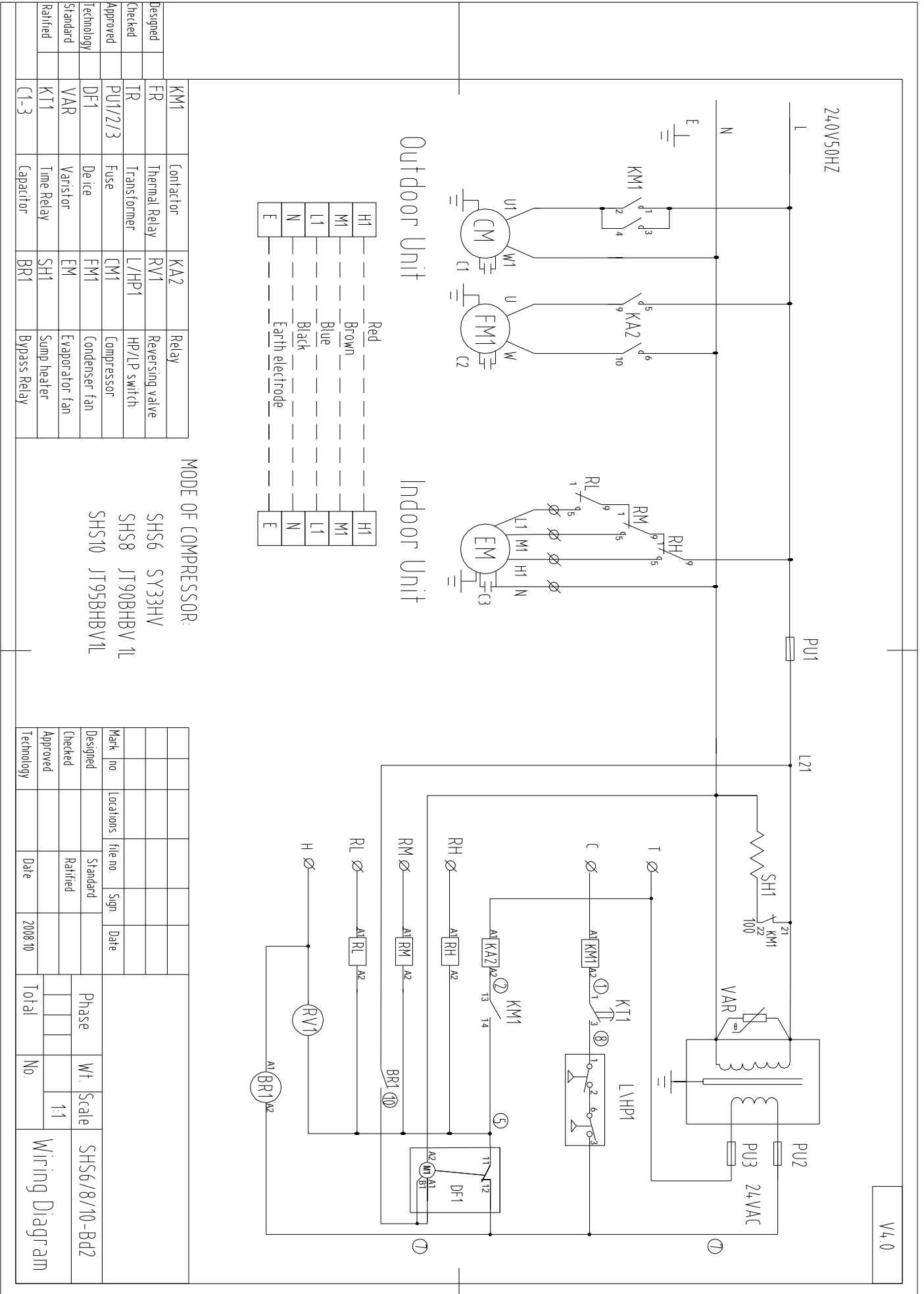

V4.0

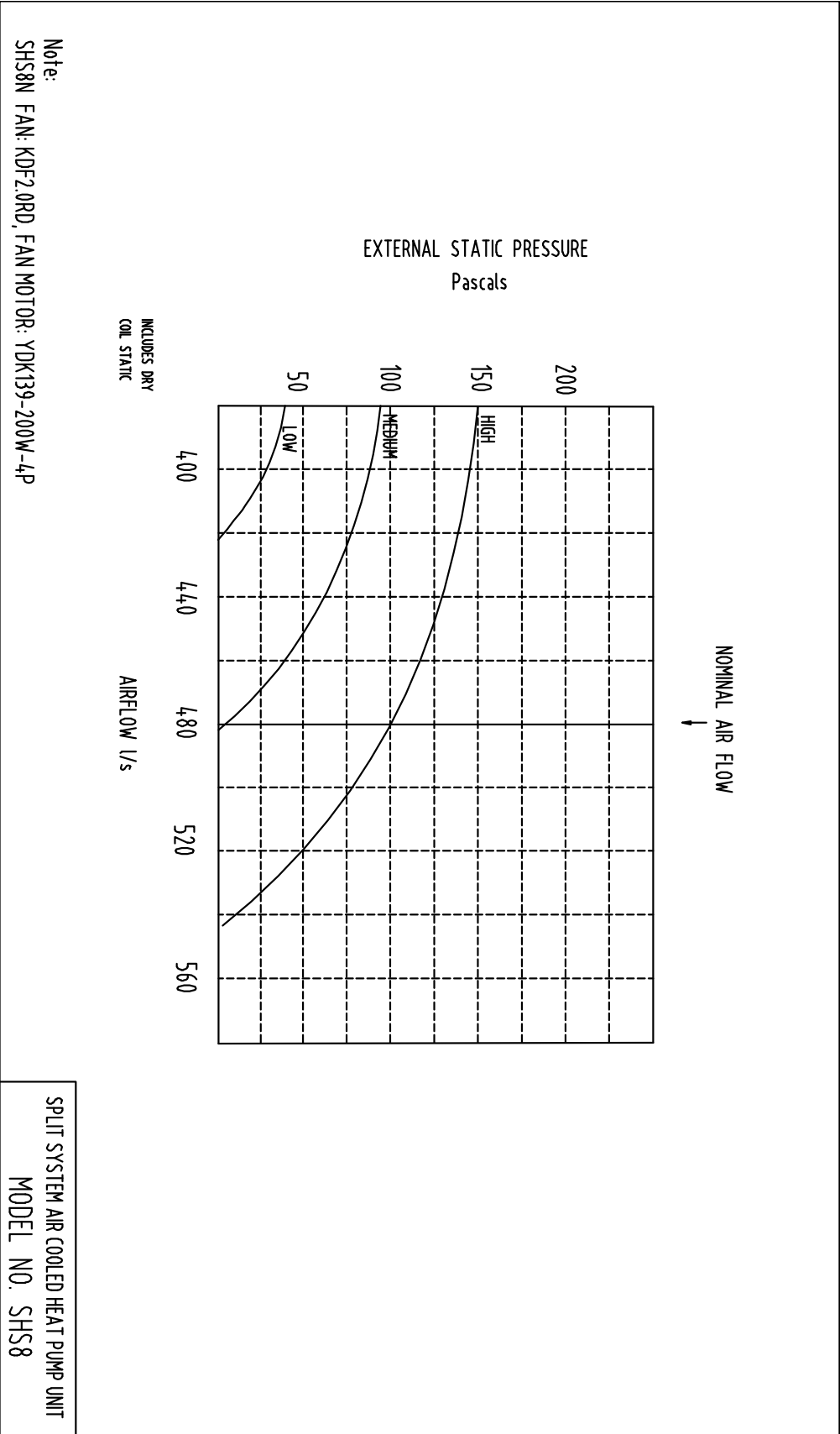

SHS8W Noise rate analysing chart

A Class: 56.4dB

Hz	dB
64Hz	59.7
125Hz	55.4
250Hz	56.0
500Hz	52.6
1000Hz	52.4
2000Hz	49.0
4000Hz	40.2
8000Hz	37.0

Noise rate analysing chart (A Class: 56.4dB) dB

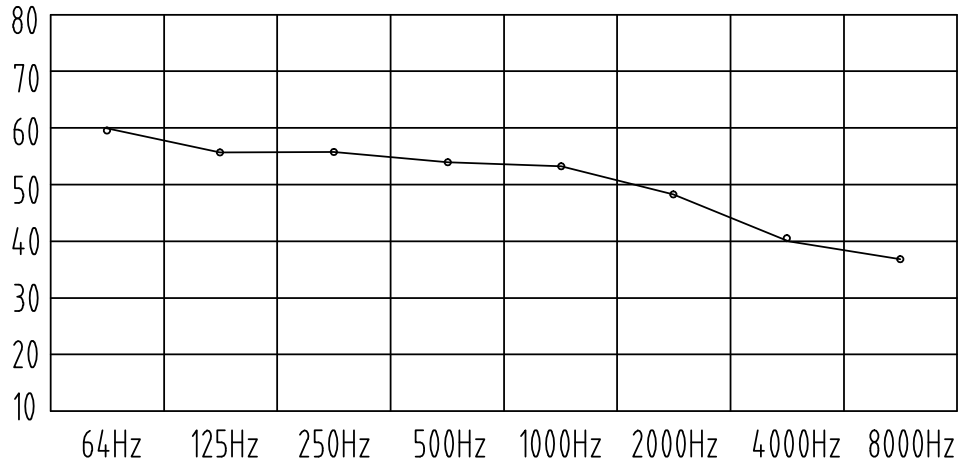

SHS8N Noise rate analysing chart

A Class: 46.5dB

Hz	dB
64Hz	54.6
125Hz	48.7
250Hz	36.8
500Hz	36.7
1000Hz	37.5
2000Hz	33.8
4000Hz	26.1
8000Hz	18.1

Noise rate analysing chart (A Class: 46.5dB) dB

