



DUNNAIR
(Aust) Pty Ltd

R410a Refrigerant

SHS6

Split Ducted Model

Performance Data

| INDOOR COIL ENTERING AIR TEMP °C | | OUTDOOR COIL ENTERING AIR TEMPERATURE °C | | | | | | | | | | | |
|----------------------------------|-------|------------------------------------------|-------------|--------|------------|-------------|--------|------------|-------------|--------|------------|-------------|--------|
| | | 30°C | | | 35°C | | | 40°C | | | 45°C | | |
| | | Tot Cap KW | Sens Cap KW | LWB °C | Tot Cap KW | Sens Cap KW | LWB °C | Tot Cap KW | Sens Cap KW | LWB °C | Tot Cap KW | Sens Cap KW | LWB °C |
| DB °C | WB °C | | | | | | | | | | | | |
| 21 | 17 | 6.4 | 3.9 | 11.2 | 6.0 | 3.8 | 11.4 | 5.7 | 3.7 | 11.8 | 5.4 | 3.7 | 12.0 |
| | 18 | 6.6 | 3.5 | 11.6 | 6.2 | 3.4 | 12.6 | 5.8 | 3.3 | 12.8 | 5.6 | 3.1 | 13.0 |
| | 19 | 6.8 | 3.0 | 13.2 | 6.2 | 3.0 | 12.8 | 6.1 | 2.8 | 13.8 | 5.8 | 2.7 | 14.0 |
| | 20 | 7.0 | 2.6 | 14.2 | 6.6 | 2.6 | 14.5 | 6.3 | 2.4 | 14.8 | 6.1 | 2.3 | 15.0 |
| 23 | 17 | 6.4 | 4.7 | 11.1 | 6.1 | 4.6 | 11.4 | 5.7 | 4.4 | 11.7 | 5.4 | 4.3 | 12.0 |
| | 18 | 6.6 | 4.3 | 12.2 | 6.2 | 4.2 | 12.3 | 5.8 | 4.0 | 12.7 | 5.6 | 3.9 | 12.9 |
| | 19 | 6.8 | 3.5 | 14.2 | 6.2 | 3.5 | 13.4 | 6.1 | 3.4 | 13.8 | 5.8 | 3.4 | 14.0 |
| | 20 | 7.0 | 3.4 | 14.2 | 6.6 | 3.4 | 14.4 | 6.3 | 3.2 | 14.8 | 6.1 | 3.1 | 15.0 |
| | 21 | 7.3 | 3.0 | 14.4 | 6.6 | 2.9 | 14.8 | 6.5 | 2.7 | 15.7 | 6.3 | 2.6 | 15.8 |
| 25 | 17 | 6.4 | 5.4 | 11.1 | 6.1 | 5.2 | 11.4 | 5.8 | 5.0 | 11.7 | 5.5 | 4.9 | 12.0 |
| | 18 | 6.6 | 5.2 | 12.2 | 6.2 | 5.1 | 12.5 | 5.8 | 4.8 | 12.8 | 5.6 | 4.6 | 13.0 |
| | 19 | 6.8 | 5.0 | 13.1 | 6.2 | 5.0 | 13.4 | 6.1 | 4.3 | 13.7 | 5.8 | 4.2 | 14.0 |
| | 20 | 7.0 | 4.8 | 14.2 | 6.4 | 4.5 | 14.5 | 6.3 | 4.0 | 14.8 | 6.0 | 3.8 | 15.0 |
| | 21 | 7.3 | 4.6 | 15.4 | 6.6 | 4.1 | 15.5 | 6.5 | 3.5 | 15.6 | 6.3 | 3.4 | 15.8 |
| 27 | 17 | 6.4 | 6.0 | 11.0 | 6.1 | 5.8 | 11.4 | 5.9 | 5.6 | 11.5 | 5.7 | 5.4 | 11.7 |
| | 18 | 6.6 | 5.8 | 12.1 | 6.2 | 5.6 | 12.3 | 6.0 | 5.4 | 12.6 | 5.8 | 5.3 | 12.8 |
| | 19 | 6.8 | 5.6 | 13.1 | 6.2 | 5.4 | 13.2 | 6.1 | 5.2 | 13.7 | 5.8 | 5.1 | 13.9 |
| | 20 | 7.0 | 5.4 | 14.2 | 6.5 | 5.3 | 14.3 | 6.2 | 4.7 | 14.8 | 6.0 | 4.6 | 15.0 |
| | 21 | 7.3 | 5.0 | 15.1 | 6.6 | 4.9 | 15.5 | 6.6 | 4.4 | 15.7 | 6.3 | 4.3 | 15.8 |
| 29 | 17 | 6.4 | 6.4 | 10.9 | 6.4 | 6.3 | 11.1 | 6.1 | 6.0 | 11.3 | 5.8 | 5.8 | 11.5 |
| | 18 | 6.6 | 6.3 | 11.9 | 6.5 | 6.2 | 12.2 | 6.2 | 5.9 | 12.5 | 5.9 | 5.8 | 12.7 |
| | 19 | 6.8 | 6.1 | 13.0 | 6.6 | 6.0 | 13.3 | 6.2 | 5.8 | 13.5 | 5.9 | 5.7 | 13.7 |
| | 20 | 7.0 | 5.8 | 14.1 | 6.6 | 5.7 | 14.4 | 6.3 | 5.5 | 14.7 | 6.1 | 5.4 | 14.9 |
| | 21 | 7.3 | 5.4 | 15.1 | 6.9 | 5.3 | 15.3 | 6.5 | 5.1 | 15.6 | 6.2 | 5.0 | 15.8 |
| 31 | 17 | 6.4 | 6.4 | 11.3 | 6.6 | 6.6 | 11.3 | 6.3 | 6.3 | 11.3 | 6.2 | 6.2 | 11.3 |
| | 18 | 6.6 | 6.4 | 11.7 | 6.6 | 6.6 | 11.9 | 6.3 | 6.3 | 12.2 | 6.2 | 6.2 | 12.4 |
| | 19 | 6.8 | 6.6 | 12.9 | 6.7 | 6.5 | 13.1 | 6.3 | 6.2 | 13.4 | 6.2 | 6.2 | 13.6 |
| | 20 | 7.0 | 6.5 | 14.1 | 6.7 | 6.4 | 14.4 | 6.3 | 6.2 | 14.7 | 6.2 | 6.2 | 14.9 |
| | 21 | 7.3 | 6.2 | 15.1 | 6.7 | 6.1 | 15.3 | 6.5 | 5.9 | 15.6 | 6.3 | 5.8 | 15.8 |

Capacity multipliers should be applied to the above capacities to adjust for reduced or increased air flow.

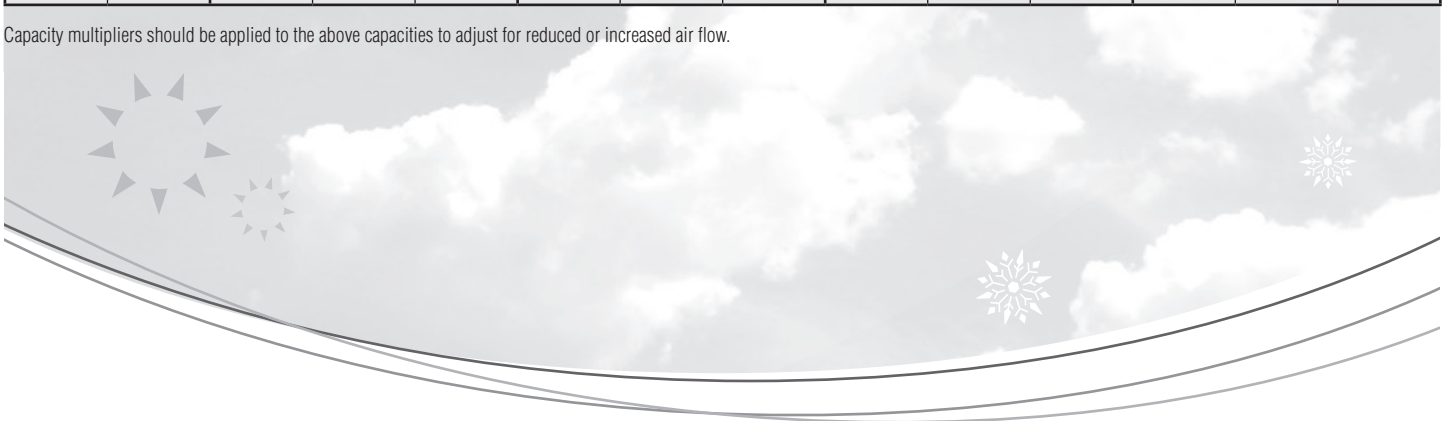

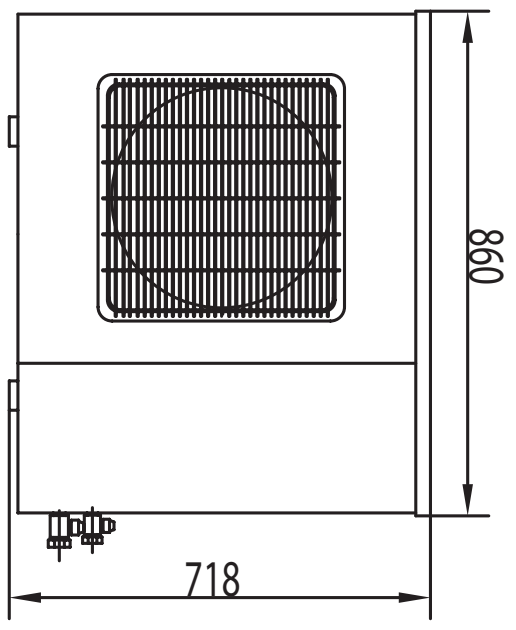
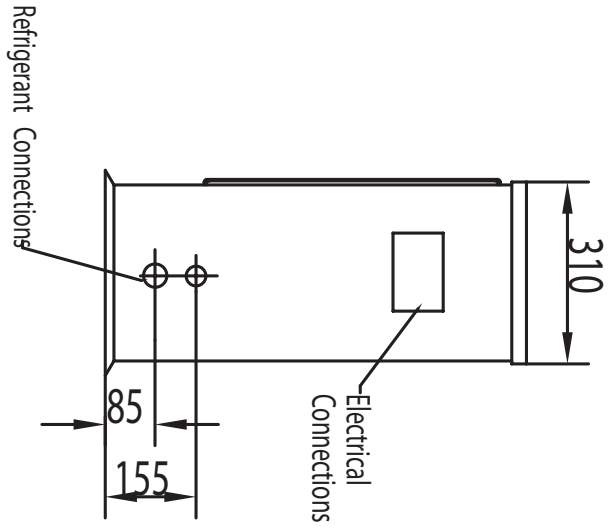

OUTDOOR UNIT INSTALLED WEIGHT 65 kg

For units with

R410a/R407C/R22

| | | | |
|-----------------------------|---------------------------------|-----------------------------------------------|----------------------|
| DRAWN BY: Chen Cheng | DATE: 7th Jan.10 | TITLE: Split System Air Cooled Heat Pump Unit | |
| APPROVED Q.A.: Li Meifen | APPROVED ENG.: Zhang Jingfei | SHS TYPE | |
| MODEL: SHS6WBd2 | DRAWING NO.: 01 | ISSUE: 01 | SHEET SIZE: A4 |

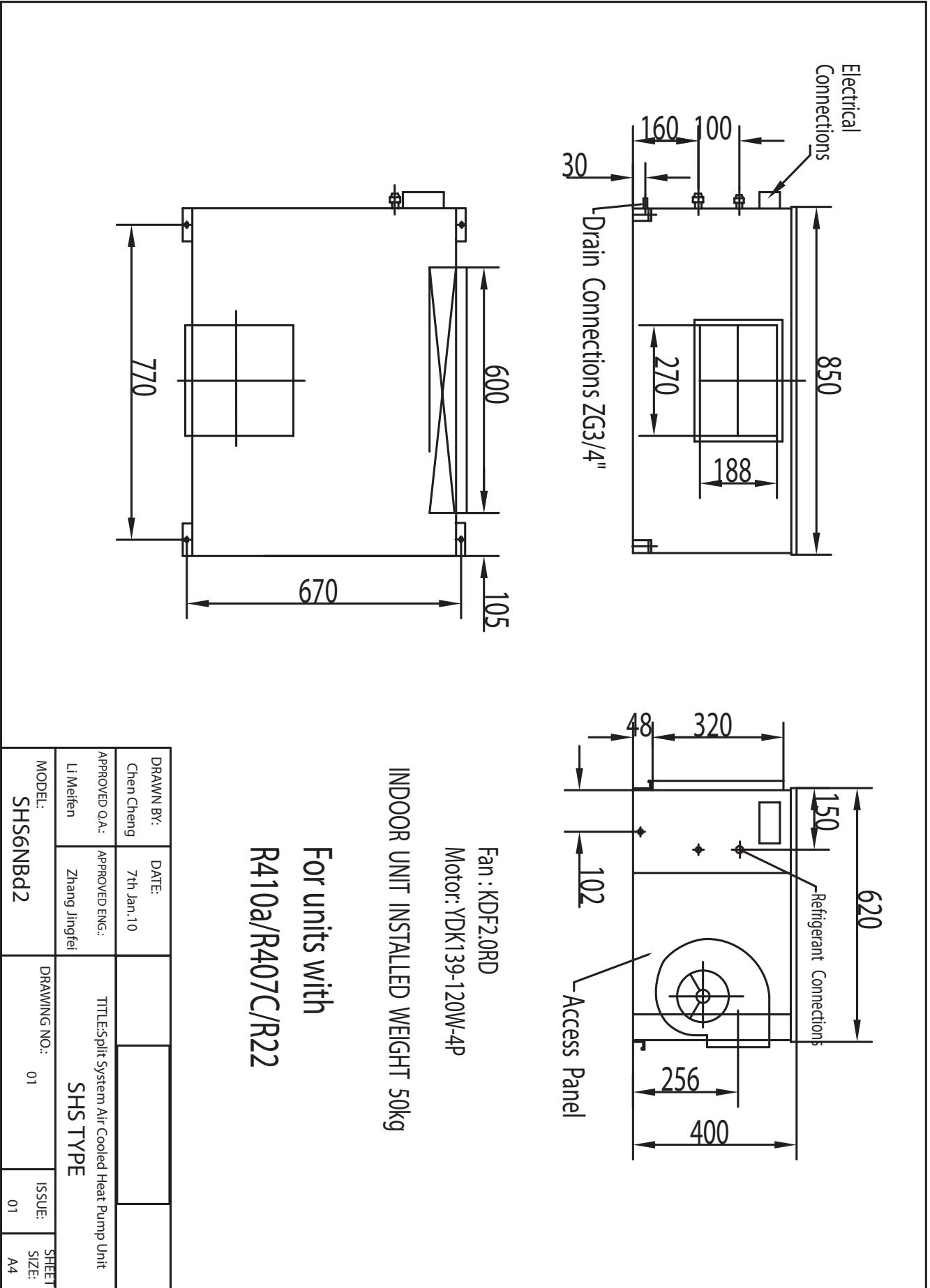

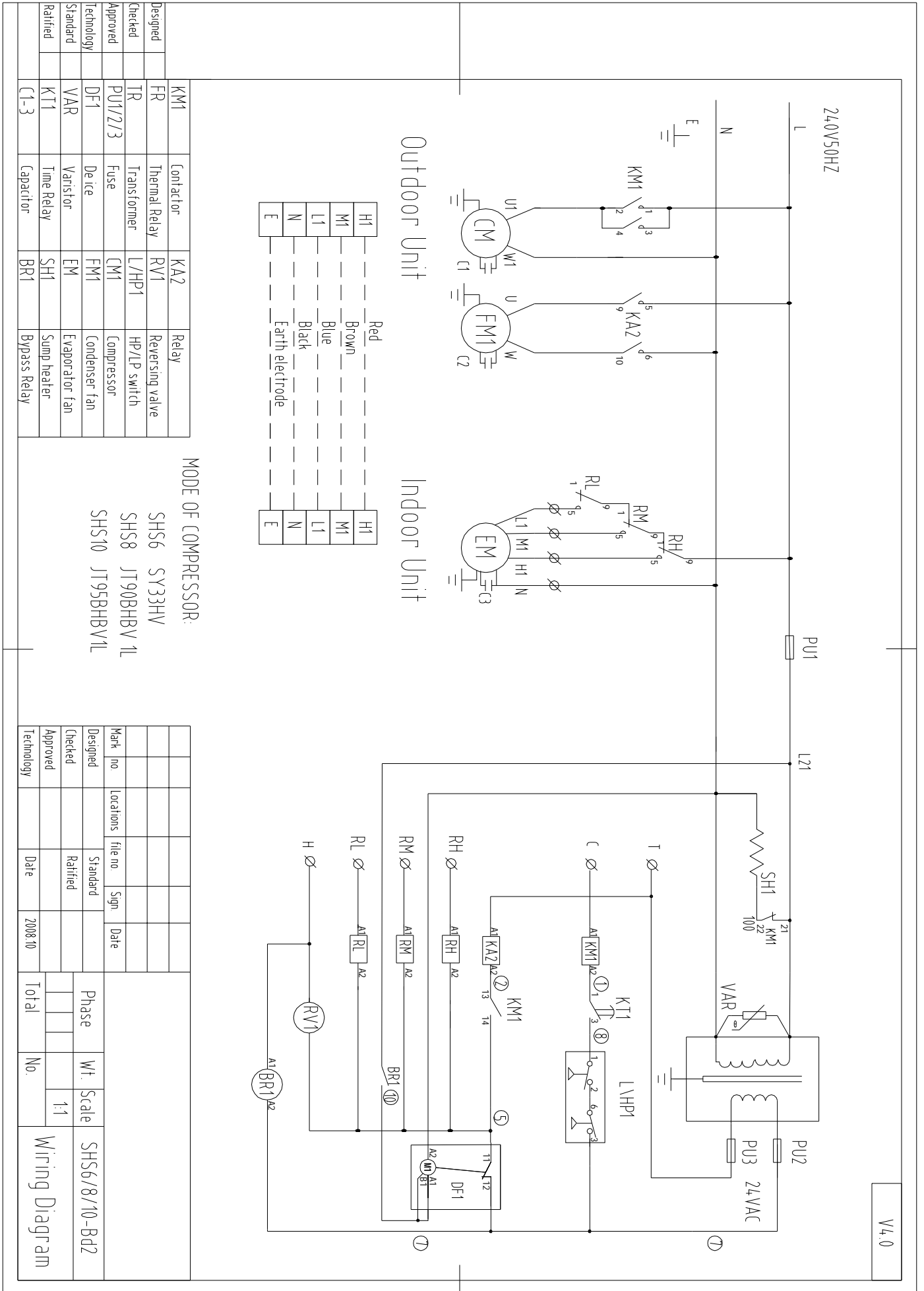

| Mark | no | Locations | file no | Sign | Date | Phase | Wt. | Scale | SHS6/8/10-BD2 |
|----------------|----|-----------|---------|------|------|-------|-----|-------|---------------|
| Designed | | | | | | | | | |
| Checked | | | | | | | | | |
| Approved | | | | | | | | | |
| Technology | | | | | | | | | |
| Standard | | | | | | | | | |
| Approved | | | | | | | | | |
| Technology | | | | | | | | | |
| Date | | | | | | Total | | No. | |
| 2008.10 | | | | | | | | | |
| Wiring Diagram | | | | | | | | | |

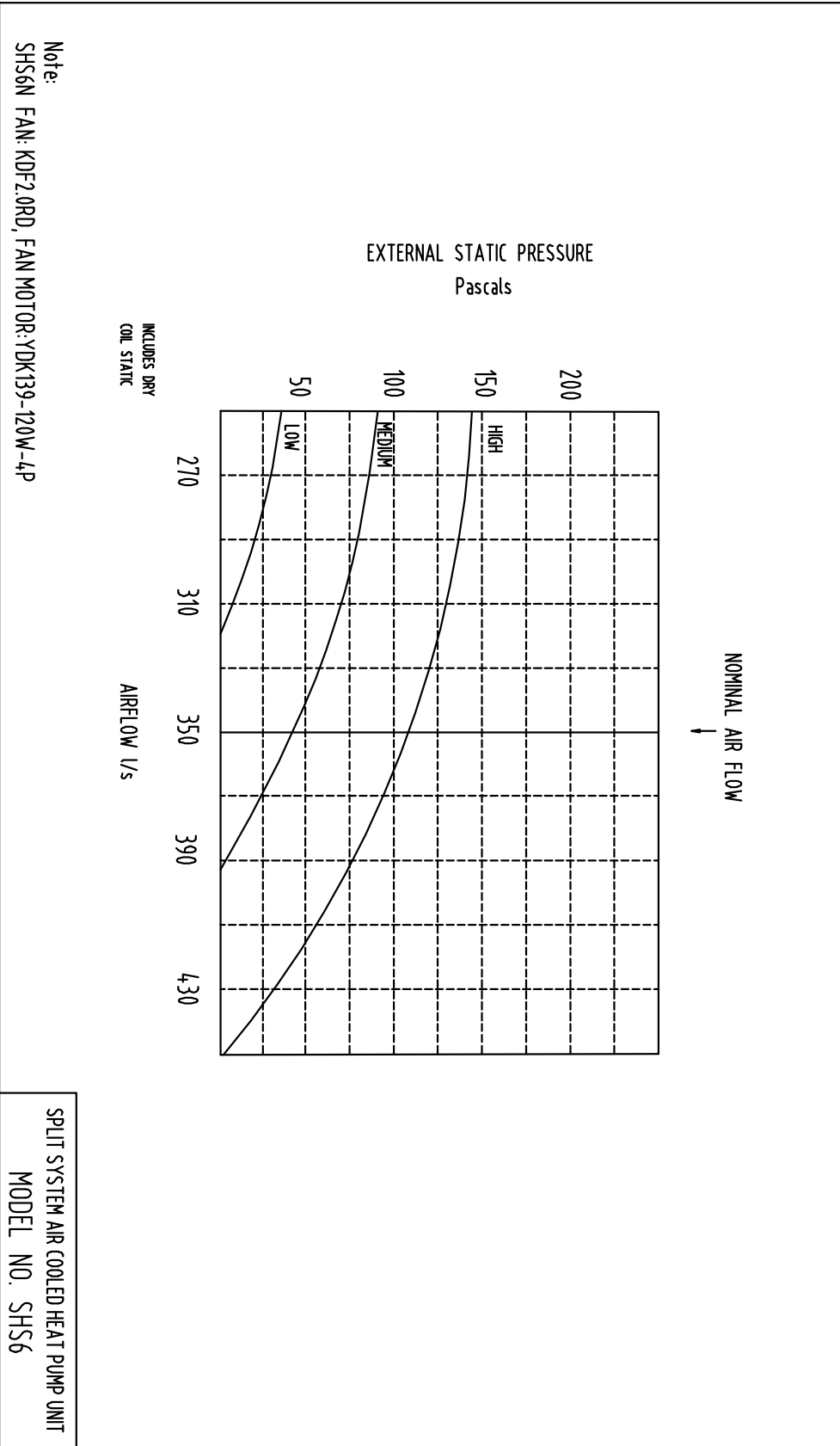

SHS6W Noise rate analysing chart

A Class: 55.5dB

| Hz | dB |
|--------|------|
| 64Hz | 59.7 |
| 125Hz | 56.0 |
| 250Hz | 55.4 |
| 500Hz | 52.5 |
| 1000Hz | 50.4 |
| 2000Hz | 47.0 |
| 4000Hz | 39.2 |
| 8000Hz | 34.3 |

Noise rate analysing chart (A Class: 55.5dB) dB

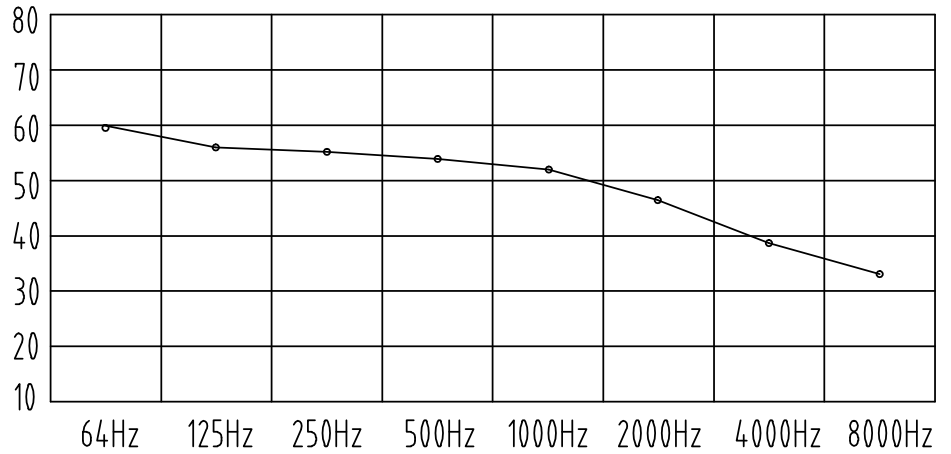

SHS6N Noise rate analysing chart

A Class: 47.8dB

| Hz | dB |
|--------|------|
| 64Hz | 55.9 |
| 125Hz | 50.2 |
| 250Hz | 42.3 |
| 500Hz | 37.7 |
| 1000Hz | 37.5 |
| 2000Hz | 35.4 |
| 4000Hz | 26.1 |
| 8000Hz | 17.5 |

Noise rate analysing chart (A Class: 47.8dB) dB

