

**MSW132
MODULAR WATER COOLED
RECIPROCATING CHILLER**

MV6 Control

**Refrigerant:
R22 Standard**

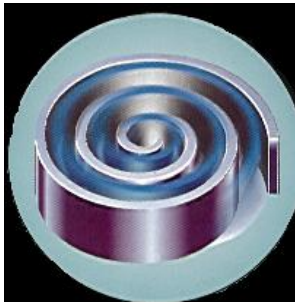

**NOMINAL CAPACITY (R22)
118 TO 1416 kW(R)**

Features

FLEXIBILITY IN DESIGN

A Multistack chiller is a bank of individual chiller modules connected in parallel to operate as a single machine. Each MSW132 module contains two completely independent refrigeration circuits. Cooling capacity is matched to load demand by varying the number of refrigeration circuits in operation.

COMPACT AND SPACE-SAVING

With each module approximately 550mm wide, you can install these quiet, compact units in confined, smaller spaces. In new buildings, you can reduce the size of plant rooms and save on structural costs.

LOWER INSTALLATION COST

The compact size of each chiller module means easy access via standard lifts and standard doorways. You don't need expensive cranes or special rigging.

Connecting the modules is simple - you only have four pipes. An active link connects electrical power. Clip in the control connections and you're in business. Fast.

ADD-ON FLEXIBILITY

Each module in the Multistack system delivers nominally 118 kW of cooling and contains two compressors, two separate evaporators 2 separate condensers and controls.

As many as 12 modules can be connected together as a Multistack chiller bank, producing a total of nominally 1416 kW. A Multistack chiller bank has inbuilt flexibility useful in tenancy changes and strata title applications.

PEAK ECONOMY AT ALL LOADS

Automatic scheduling of the chiller's compressors allows Multistack to match the fluctuating cooling load and conserve energy with each unit running at its peak economy. The bottom line is lower cost per rentable sq. metre.

MICRO PROCESSER CONTROL

A fully computerised control and monitoring system runs the Multistack chiller bank and schedules each compressor either off or on and low or high speed, depending on the changing air conditioning or cooling load. The system continuously and comprehensively monitors total operating conditions of all refrigeration circuits of the chiller bank.

FILTRATION

The strainers in the condenser water circuit are an integral part of the chiller. They are fitted inside the water distribution header before the heat exchanger. The developed area of the filter is large and therefore only creates an initial clean filter pressure drop of 5 kPa. This is an economical in-line filter solution providing good filtration with a No. 60 mesh screen. These filters are 316 stainless steel and can be easily removed for cleaning purposes.

UNCOMPLICATED OPERATION

All systems in the chiller are controlled by the dedicated computer which records and displays the operating parameters of the chiller bank in plain English (other languages are available).

UNPARALLELED DEPENDABILITY

Each slave module is identical. In the event of malfunction in a refrigeration circuit, the computer selects the next available standby circuit to provide back up.

For critical air conditioning and industrial process cooling a Multistack modular chiller inherently provides economical standby capacity and unparalleled dependability.

The use of standard components in our chillers also enhances system reliability.

ENVIRONMENT FRIENDLY

Multistack chillers operate quietly and currently use the well-proven, non-toxic R22 refrigerant, approved under the Montreal Protocol for sale until 2030.

THE TOUGHEST QUALITY CODE IN EUROPE

Multistack brazed plate heat exchangers are all produced within the established and applied quality system for fabrication of brazed Heat Exchangers, that of the TUV CERT Certification Body of Rheinisch-Westfalischer TUV.

This code requires an audit of the manufacturing process, and a report has been furnished that the requirements are according to ISO 9002.

Every single heat exchanger has to pass quality control, over pressure and leak tests using state of the art helium detectors.

Multistack is an accredited manufacturer to ISO 9002.

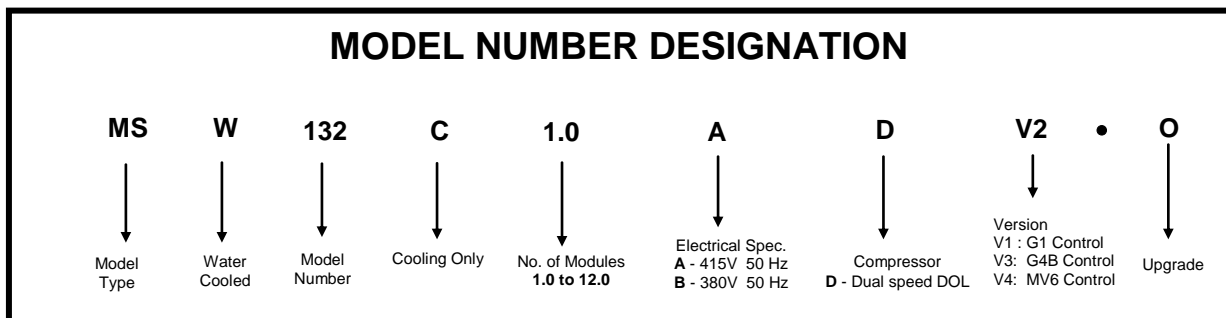

Computer Control System 'MV6'

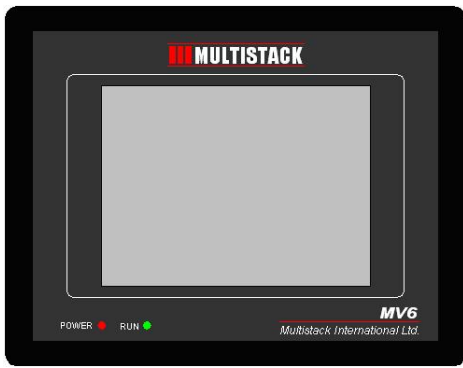

COMPUTER CONTROL

A **MV6** computer control with 5.7" touch panel and monitoring system runs the Multistack chiller bank and schedules each compressor off or on and capacity control of stages, depending on the changing cooling load. The system continuously and comprehensively monitors total operating conditions of all refrigeration circuits of the chiller bank. Maximum 32 compressors can be monitored.

TEMPERATURE CONTROL

Multistack chiller is controlled either by entering water temperature or leaving water temperature. For variable water flow (VWF) models, controller will use leaving chilled water temperature to operate.

SYSTEM DATA AND VARIABLES DISPLAY

A comprehensive range of Chiller system / slave data and variable settings can be selected from the Multistack computerised monitoring system for display on the menu.

System Information: Water entering / leaving Temperature.

Ambient temperature
Loading / demand loading Capacity
Load / unload time delay
% of faults before remote alarm.
Lead compressor
Compressor run status.

Slave Information: Suction and discharge pressure.

Evaporate Temperature
Water leaving Temperature
Faults status

System Variables Settings

Password settings
Entering / leaving water temperature
Lead Compressor
Integrating time
Economy offset.
Load / unload time delay
Time and Date.

Slave Variables Settings

Suction and discharge pressure protection
Evaporating temperature protection
Compressor load / unload time delay.

COMPRESSOR SEQUENCE

MV6 accumulate running hours of each compressor and hence establish working sequence. A standby compressor with least working hours will be activated once call when loading. Same as a compressor with most working hours will be stopped once unloading.

LOAD PROFILE

Cooling capacity of Multistack chiller is divided into 10 sections from 0% to 100%. Controller accumulate the working time of the chiller in each section and each compressor automatically.

FAULT REVIEW

It displays the last 60-recorded faults identified with time and date, system temperatures, individual refrigeration circuit temperatures and type of abnormal conditions.

PASSWORD

For service and maintenance, only personnel with appropriate password can access and modify the controller.

INDIVIDUAL REFRIGERATION SYSTEM MONITORING

Conditions such as high pressure, low pressure, refrigerant temperature, leaving chilled water temperature of individual refrigeration circuits and system conditions are monitored.

SAFETY PROTECTION FEATURES

High pressure cut out.
Low pressure cut out.
Compressor motor protection.
Low leaving chilled water temperature cut out for each slave and system.
Low suction pressure.
High discharge temperature.

Phase failure.
Phase sequence.
High oil differential pressure cut out.

REMOTE CONTROL & MONITORING (RCM)- OPTIONAL

MV6 is fitted with RS485 serial port, which enables remote control monitoring (RCM) :

1. Connect to PC Under software optional supplied by Multistack, and compatible with Window version, remote control is built to monitor chiller. Maximum communication cable length is 1200m.
2. MV6 is opened to ASCII agreement and communicated with BAS.
3. With Ethernet-card and a unique IP address, customer can built up its data transmission system via internet... of which is optionally supplied by Multistack.

Chiller Selection

STANDARD PERFORMANCE DATA

Multistack ratings are based on the following conditions:

1. 5.5K chilled water temperature drop.
2. 5.5 L/s chilled water flow rate/module.
3. 30 kPa chilled water pressure drop.
4. 5.6 K condenser water temperature rise.
5. 7.0 L/s condenser water flow rate/module.
6. 28 kPa condenser water pressure drop.
7. 0.088m² K/kW fouling factor.

EXAMPLE:-

TO SELECT A MULTISTACK CHILLER TO MEET THE FOLLOWING REQUIREMENTS FOLLOW STEPS 1 TO 5 BELOW

Leaving chilled water temperature (LCHW)	7.0°C
Entering chilled water temperature (ECHW)	12.0°C
Chilled water flow rate (CHWF)	21.5 L/s
Leaving condenser water temperature (LCW)	35.0°C
Entering condenser water temperature (ECW)	29.4°C

1. Determine cooling capacity required (kW)

$$\begin{aligned} \text{kW} &= \text{CHWF} \times (\text{ECHW} - \text{LCHW}) \times 4.187 \\ &= 21.5 \times (12-7) \times 4.187 \\ &= 450 \text{ kW required} \end{aligned}$$

2. From capacity chart below,

- 1 module at stated conditions will achieve 118 kW.
This is known as the achieved capacity.

- kW input is 32.2 kW.

Divide the required capacity by achieved capacity at specified conditions to determine required number of modules:

$$= \frac{450 \text{ kW required}}{118 \text{ kW achieved}} = 3.81 \text{ modules}$$

∴ Select 4 modules
Capacity of 4 modules = 4 X 118 = 472 kW.

3. Determine required chilled water flow rate (CHWF) at 472 kW

$$= \frac{\text{kW (achieved)}}{(\text{ECHW} - \text{LCHW}) \times 4.187}$$

$$\begin{aligned} &= \frac{472}{(12 - 7) \times 4.187} \\ &= 22.5 \text{ L/s total flow} \\ \text{or } &\frac{22.5}{4} = 5.6 \text{ L/s per module.} \end{aligned}$$

4. Determine required condenser flow rate at 472 kW

$$\begin{aligned} &= \frac{\text{kW} + \text{kW input}}{(\text{LCW} - \text{ECW}) \times 4.187} \\ &= \frac{472 + (32.2 \times 4)}{5.6 \times 4.187} \\ &= 25.6 \text{ L/s total flow} \\ \text{or } &\frac{25.6}{4} = 6.4 \text{ L/s per module} \end{aligned}$$

5. Determine water side pressure drop (PD) under new conditions as follows:

Standard flow & PD for CHILLED water are 5.5 L/s per module and 30 kPa respectively.

Standard flow and PD for CONDENSER water are 7.0 L/s per module and 28 kPa respectively.

- a. Express required flow as a percentage of standard flow i.e. for chilled water flow of 5.6 L/s per module

$$\begin{aligned} &= \frac{5.6}{5.5} \times 100 \\ &= 101.8 \% \end{aligned}$$

- b. Using the pressure drop correction factor chart. At 101.8 % the pressure drop correction factor is 1.05

- c. Multiply PD correction factor by standard PD to obtain new PD

$$\therefore \text{NEW PD @ 5.6 L/s} = 1.05 \times 30 = 31.5 \text{ kPa}$$

Note:- Minimum Chilled Water Flow Rate Per Module: 4.9 L/s - Minimum Condenser Water Flow Rate Per Module: 6.3 L/s
Contact Multistack if lower flow rate is required.

Unit Capacity Per Module

COOLING CAPACITY

Condenser Leaving Water Temp. °C	Leaving Chilled Water Temperature R22							
	6°C		7°C		8°C		10°C	
	Unit Cap. kW.	Comp Power Input kW.	Unit Cap. kW.	Comp Power Input kW.	Unit Cap. kW.	Comp Power Input kW.	Unit Cap. kW.	Comp Power Input kW.
30	122	30.3	127	30.7	133	31.1	143	31.9
35	113.5	31.8	118	32.2	123	32.7	134	33.6
40	104	33.2	110	33.7	114	34.3	124	35.3
45	96	34.5	100	35.1	105	35.8	114	37
50	87	35.5	91	36.3	95	37.1	104	38.5

Notes

- This table is based on a 5.5 °K difference in chilled water temperature.
- Please contact your local Multistack agent if you require performance data beyond the limits of the above table.
- Interpolation is permissible. Do not extrapolate.

Physical Data Per Module

NOMINAL CAPACITY * Cooling (kW)	118
COMPRESSOR Reciprocating Hermetically Sealed 2 Speed Number per Module	2
CONDENSER Brazed Plate Type, Stainless Steel 316 Number Nominal Water Flow (L/s) Max. Working Press. Water (refrigerant) (kPa) Max. Working Press. Water (kPa) (Standard) Water Volume (L) including header	2 7.0 2400 1050 19 x 2
EVAPORATOR Brazed Plate Type, Stainless Steel 316 Number Nominal Water Flow (L/s) Max. Working Press. (refrigerant) (kPa) Max. Working Press. Water (kPa) (Standard) Water Volume (litre) including header	2 5.5 2400 1050 17 x 2
SIZE L x W x H	1250 x 550 x 1640
WEIGHT Shipping (kg) Operating (kg)	590 680
REFRIGERANT CHARGE R22 (kg)	6.5 x 2
UNIT CASING Mild Steel, Zinc annealed Substrate Powder Coated	

- * Nominal Values Based Upon:
- Chilled Water leaving temp. 7°C
 - Chilled Water entering temp. 12.5°C
 - Condenser Water leaving 35°C
 - Condenser Water entering 29.4°C

CONDENSER WATER QUALITY GUIDE

The following parameters are recommended as a guide for optimum quality of the water circulating through the condenser cooling tower circuit.

Conditions	Maximum	Affects Corrosion	Affects Scaling
Total Dissolved Solids (TDS)	700 ppm	Yes	Yes
Conductivity	1000 uS/cm	Yes	Yes
Sulphate ions (as SO ₄ ²⁻)	200 ppm	Yes	-
All iron (as Fe)	0.5 ppm	-	Yes
M alkalis (as CaCO ₃)	100 ppm	-	Yes
All hardness (as CaCO ₃)	200 ppm	-	Yes
Silica (as SiO ₂)	50 ppm	-	Yes
Chloride ions (as Cl) for materials below:			
s.s. 316	210 ppm	Yes	-
pH @ 25.0 °C	Range: 6 - 8	Yes	Yes

Important Note:

Corrosion and/or scaling may result from an excess of one condition but water quality should satisfy all conditions to prevent its occurrence. It is recommended that condenser water and water supply be regularly assessed by a reputable test laboratory to ensure maximum system protection.

- Note:- Minimum Chilled Water Flow Rate Per Module: 4.9 L/s
- Minimum Condenser Water Flow Rate Per Module: 6.3 L/s

HEAT EXCHANGER WATER PRESSURE DROP

Pressure drop correction factor for chilled and condenser water circuit.

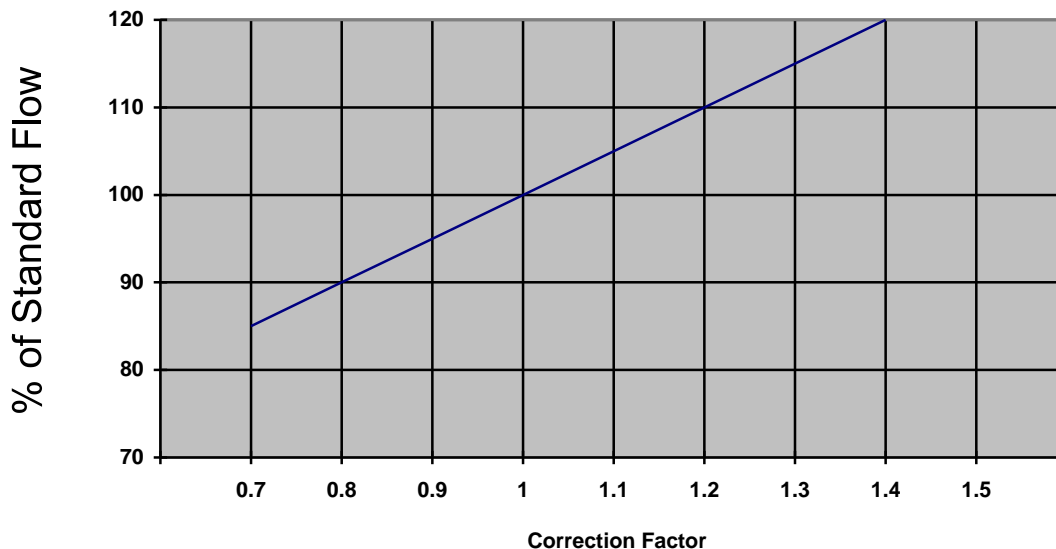

Electrical Data

Supply 380V to 415V-50Hz 3 phase.

Maximum Rated Current MRC (see table below)

- = 36.0 A (Per Half Module)
- = 72.0 A (Per Full Module)

Compressor LRA = 188.0 A

Model	MRC	No. of Compr.
MSW132/0.5	36.0	1
MSW132/1.0	72.0	2
MSW132/1.5	108.0	3
MSW132/2.0	144.0	4
MSW132/2.5	180.0	5
MSW132/3.0	216.0	6
MSW132/3.5	252.0	7
MSW132/4.0	288.0	8
MSW132/4.5	324.0	9
MSW132/5.0	360.0	10
MSW132/5.5	396.0	11
MSW132/6.0	432.0	12
MSW132/6.5	468.0	13
MSW132/7.0	504.0	14
MSW132/7.5	540.0	15
MSW132/8.0	576.0	16
MSW132/8.5	612.0	17
MSW132/9.0	648.0	18
MSW132/9.5	684.0	19
MSW132/10.0	720.0	20
MSW132/10.5	756.0	21
MSW132/11.0	792.0	22
MSW132/11.5	828.0	23
MSW132/12.0	864.0	24

Notes:

1. Where two separate supplies are used, separate circuit protection devices and warning labels indicating isolation procedures must be used (by others).
2. Design running amps is the steady state current draw at a particular set of conditions, ie. condenser and chilled water temperatures.
3. Maximum rated current is the maximum expected current draw at transient (pull down) and/or greater than design conditions.

CABLE SIZING

When selecting mains cable sizes use MRC. Allowance must be made for voltage imbalance, under voltage, ambient temperature and other conditions in compliance with AS 3000 or relevant electrical code.

MAINS CABLE ENTRY

Electrical mains entry can be made at either end of the chiller. Larger cooling capacity machine may require entry at both ends depending on current drawn and cable size. Refer Installation Manual for details.

Piping Schematic

Condenser Water

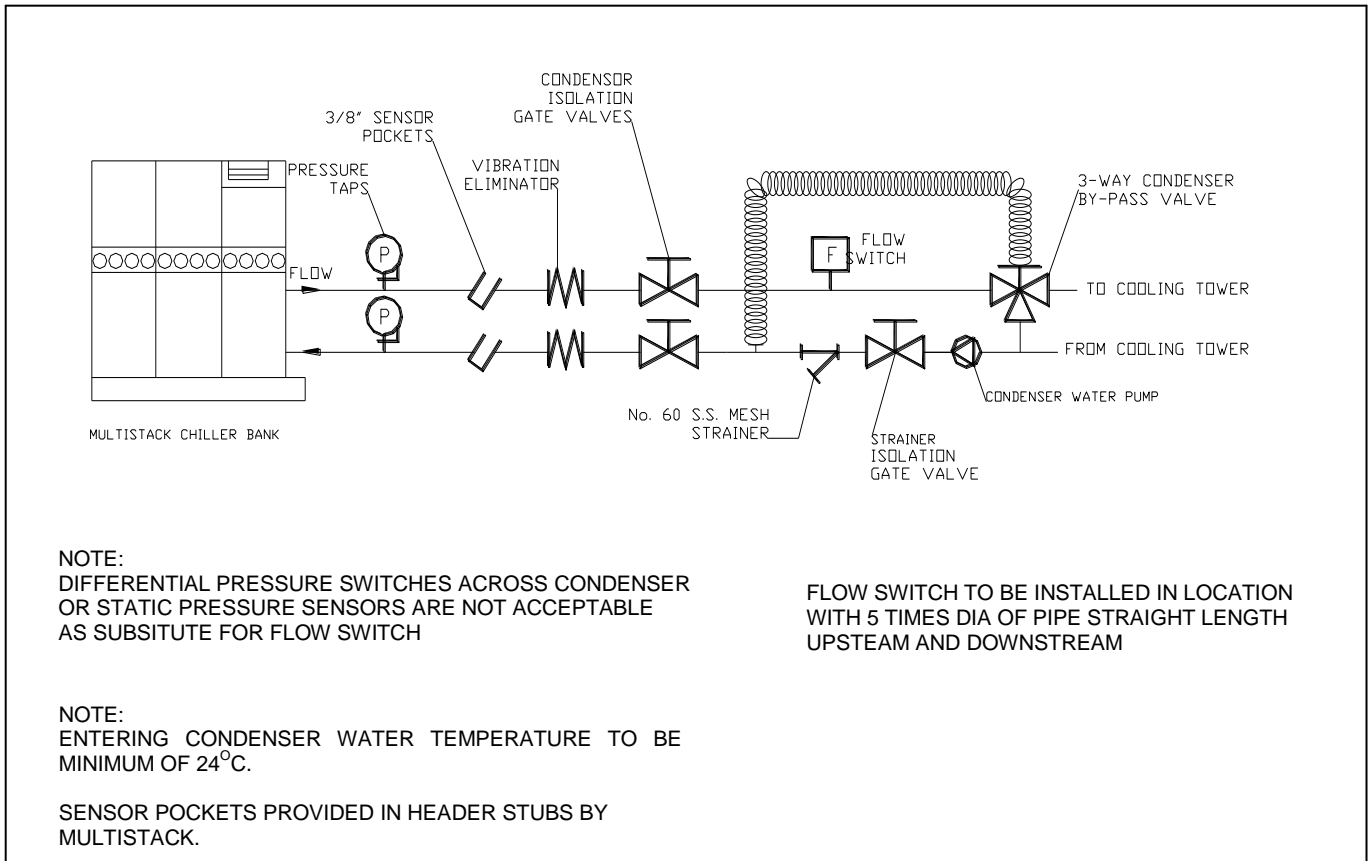

Chilled Water

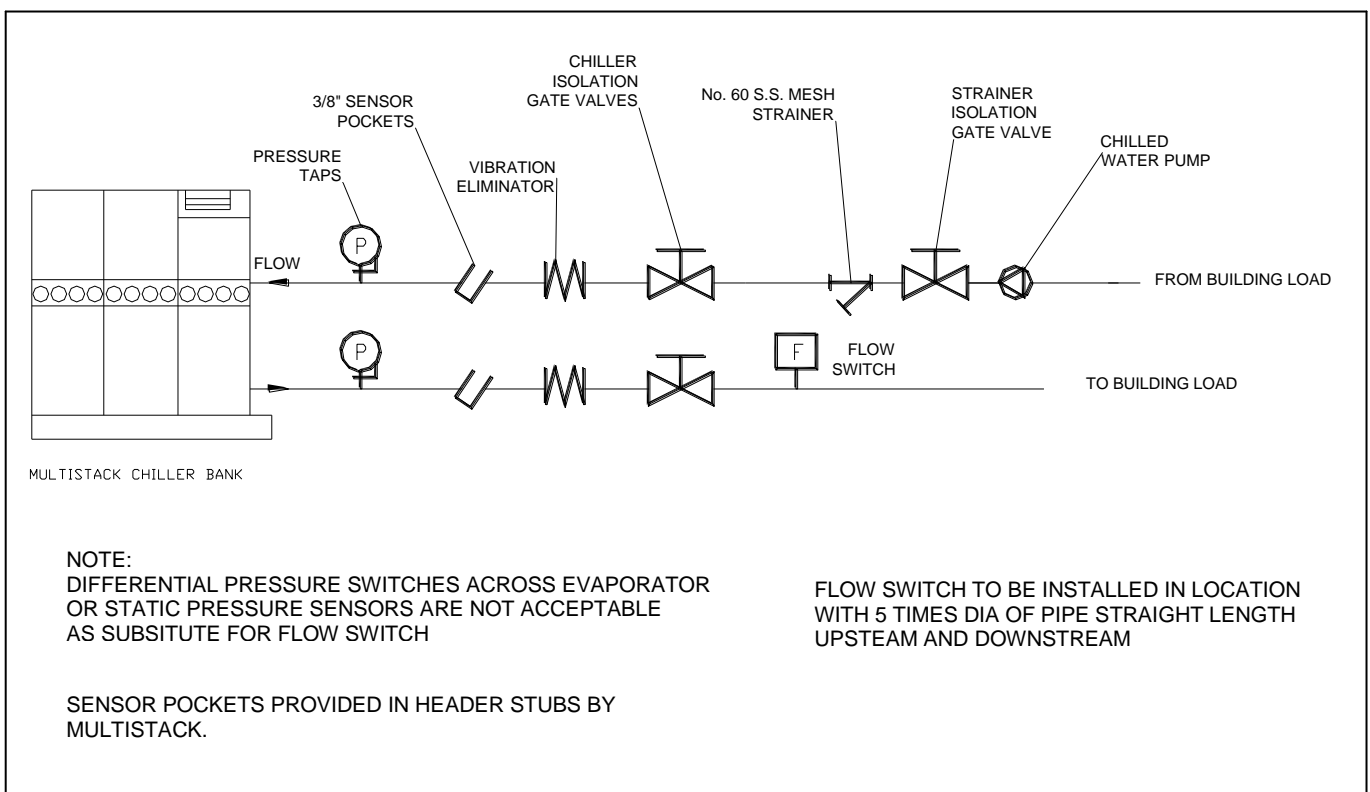

Field Wiring Diagram

Field Wiring Diagram

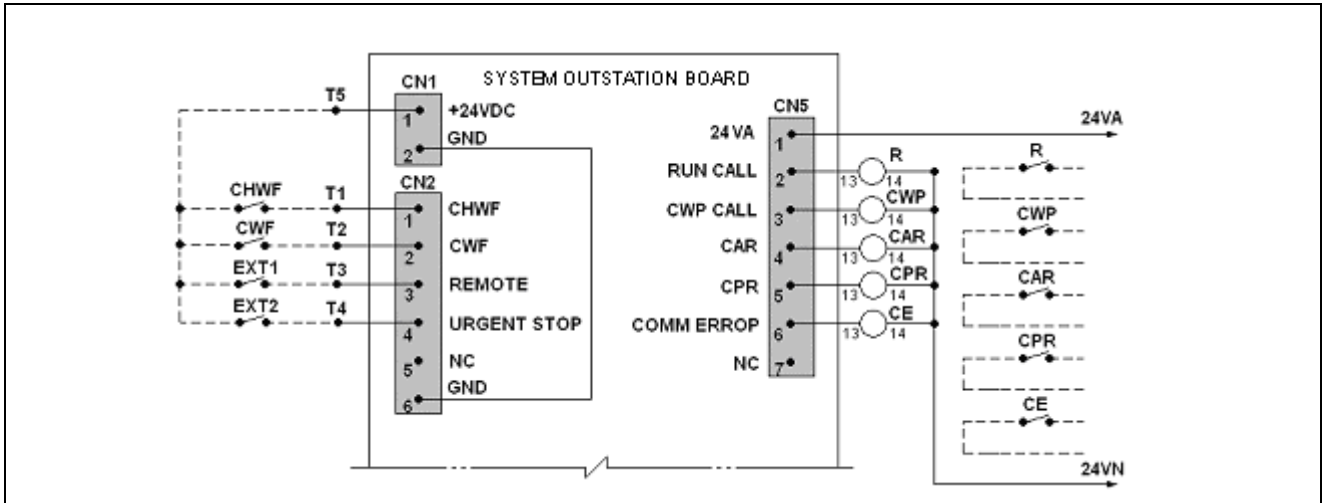

note

- CHWF —interlock contacts in series for chilled water flow switch and water pump contact auxiliary(no flow switch for VWF)
- CWF —interlock contacts in series for chilled water flow switch and water pump contact auxiliary(no flow switch for VWF)
- Ext1 —external remote on/off input
- Ext2 —external emergency stop input
- R —chiller running status output
- CWP —condenser water pump running output
- CAR —fault alarm output
- CPR —compressor running status output
- CE —Communication error alarm output

wiring note

- Control wiring to be 1mm² minimum.
- Bridge between terminals t3&t5 if ext-1 is not utilized.
- bridge between terminals t3&t5 if ext-1 is not utilized.
- free contacts have a maximum rating of 5a.
- flow switch and external interlock device are not supplied by Multistack
- wiring by Multistack —/ wiring by user-----

Physical Dimensions

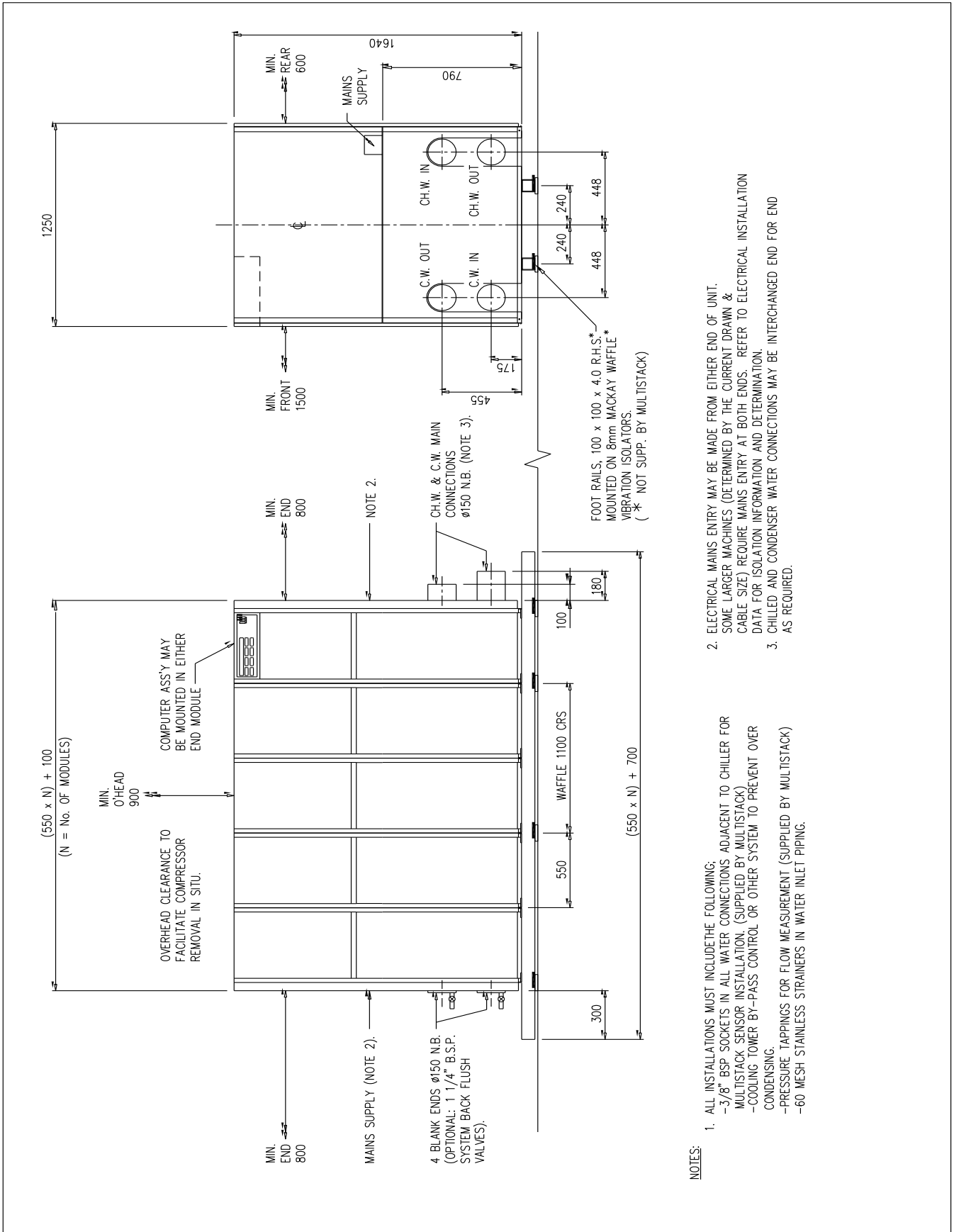

Guide Specification

WATER COOLED CHILLER SET

Supply and install where shown on plans(No) water chiller sets, of MULTISTACK design, modular type having cooling capacity schedules. The chiller shall be suitable for the addition of further cooling modules as an integrated system, if and when required.

The chiller set shall be of modular design and construction with each compressor having its own evaporator, condenser and independent refrigeration system.

The chiller shall be totally enclosed within easily removed panels.

The compressor, evaporator and condenser shall be mounted on a heavy fabricated steel chassis with an electrostatically applied powder oven baked finish.

The module's outer metal frames and panels shall be powder coated to approved colour and oven baked.

All refrigeration pipework and components including all necessary accessories shall be connected in accordance with the best refrigeration practice and shall be charged with HCFC22.

COMPRESSOR

Each module shall be equipped with high quality hermetic reciprocating compressors, factory assembled and tested.

The compressors shall be of approved manufacture, reciprocating type dual speed, hermetically sealed having adequate motor capacity to achieve the required performance. The motor shall be 3 phase, 415 VAC +/- 10% name plate voltage and shall be equipped with thermistors embedded in each winding for direct protection against overheating or single phasing.

Each compressor shall be equipped with high and low refrigerant pressure, low refrigerant suction pressure and high motor temperature safety controls.

Each chiller module shall be fitted with direct-on-line dual speed motor starters for each compressor and capable of operation for the number of starts per hour stated by compressor manufacturer.

HEAT EXCHANGERS

The heat exchangers for condenser and evaporator duty shall be manufactured from type 316 stainless steel and be of copper brazed plate construction.

The condenser and evaporator shall be suitable for a working pressure of 2400 kPa on the refrigerant side and 1050 kPa on the water side.

The cooling capacity shall be selected with a fouling factor of 0.088 m² K/kW.

CONDENSER

Nominal water flow through the condenser shall be 6.4 L/s at a maximum pressure drop of 28 kPa.

EVAPORATOR

Nominal water flow through the evaporator shall be 5.1 L/s at a maximum pressure drop 30 kPa.

Each evaporator shall be provided with low refrigerant and low chilled water temperature cut out.

CENTRAL CONTROL SYSTEM

The chiller shall be complete with its own computer based inbuilt capacity controls adjusting both proportionally and integrally to match the required load.

Set point adjustment and interrogation of unit shall be via 8 key touch pad panel mounted for convenient access.

The controller shall have an auto restart after power failure if all safety interlocks are clear. All set points shall be held in an EEPROM .

THE CONTROL SYSTEM INCORPORATES THE FOLLOWING FEATURES:

1. Fault memory - the last 25 faults shall be logged and identified with time, date and full operating conditions to allow for complete service review.
2. Full status indication of compressors, showing run/fault status and all individual system operating conditions.
3. Continual update of load profile data.
4. Automatic sequencing of compressors on 24-hour cycle.
5. Display of main chilled and condenser water entering and leaving temperatures.
6. Timing circuits to limit each compressor starting frequency.

CHILLED WATER MAINS AND HEADERS

Each module shall include 150 NB supply and return header pipes for both chilled and condenser water. All headers shall be constructed of mild steel and housed within panelled enclosure. Headers shall be suitable for 1050 kPa working pressure. Grooved connections shall be provided at each end for use with Victaulic couplings.

All headers shall be coated for corrosion protection. The chilled water headers shall be insulated with closed cell nitrogen filled foam having an integral vapour seal. Insulation shall be at least 19mm thick and self-extinguishing type.

INSTALLATION

The complete chiller assembly shall be mounted off the floor on anti-vibration mountings and rails to be supplied by the contractor.

The contractor shall supply, install, wire and commission a flow switch in the condenser and chilled water pipe work external to the chiller. These flow switches shall stop and/or prevent operation of the chiller in an event of no flow or reduced flow below 85% of design conditions. (Pressure differential or static pressure sensing devices are not acceptable as a substitute for velocity sensors.)

The contractor shall provide flexible pipe connections on water pipes leaving and entering chiller set.

COMMISSIONING

Supervision of connection and commissioning of modules shall be carried out by the manufacturer or factory trained representatives of the manufacturer.



FOR EXPORT
MULTISTACK INTERNATIONAL LIMITED
10 COCHRANES ROAD, MOORABBIN, VICTORIA 3189, AUSTRALIA
TELEPHONE: 61 3 8552 1200 FACSIMILE 61 3 8552 1201
Email: sales@dunnair.com.au

Since MULTISTACK INTERNATIONAL LIMITED has a policy of continuous product improvement, it reserves the right to change design and specification without notice. Multistack supplied by DunnAir international Limited (a wholly owned subsidiary of Multistack International Limited).